



STATEMENT OF ENVIRONMENTAL EFFECTS

Stonehenge Feedlot

Jardana Pty Ltd

Date: 27 October 2020



Prepared by:

Matt Norton (B. App. Sc.)
Director

Agricultural Development Services Australia Pty Ltd (AgDSA)
PO Box 292
Toowoomba QLD 4350

Document Control						
Revision	Description	Date Issued	Prepared by	Signed	Reviewed by	Signed
Rev 0	Draft	6/10/2020	MRN	<i>M. Naste</i>	PJW	<i>PJW</i>
Rev A	Final	27/10/2020	MRN	<i>M. Naste</i>	PJW	<i>PJW</i>

CONTENTS

1	INTRODUCTION.....	6
2	CONTEXT AND SETTING.....	7
2.1	Subject Site.....	7
2.2	Climate.....	8
2.3	Receptors and Surrounding Land Use.....	10
2.4	Topography.....	10
2.5	Land and Soil.....	13
2.6	Surface Water.....	16
2.7	Groundwater.....	16
2.8	Flora and Fauna.....	19
2.9	Wetlands.....	19
2.10	Cultural Heritage.....	21
3	PROPOSED DEVELOPMENT.....	22
3.1	Overview.....	22
3.2	Traffic.....	25
3.3	Controlled Drainage Area & Stormwater Management.....	27
3.4	Site Suitability.....	30
4	ENVIRONMENTAL MANAGEMENT PLAN.....	33
5	PLANNING FRAMEWORK.....	37
5.1	Glen Innes Severn Council.....	37
5.2	State Environmental Planning Policies.....	45
6	CONCLUSION.....	47
7	REFERENCES.....	48

FIGURES

Figure 1 – Climate Data.....	8
Figure 2 – Locality.....	9
Figure 3 – Sensitive Receptors and Surrounding Land Use.....	11
Figure 4 – Topography.....	12
Figure 5 – Soils.....	15
Figure 6 – Surface Water Features.....	17
Figure 7 – Groundwater Bores.....	18
Figure 8 – Native Vegetation Map.....	20

PHOTOGRAPHS

Photograph 1 – Subject site showing transition of soil types.....	14
---	----

TABLES

Table 1 – Relevant Land Parcels.....	7
Table 2 – Sensitive Receptors.....	10
Table 3 – Land and Soil Capability.....	13
Table 4 – Traffic.....	26
Table 5 – Controlled Drainage Area.....	27
Table 6 – Sedimentation Basin Design.....	28
Table 7 – S-Factor Calculation.....	30
Table 8 – Environmental Risk Assessment Matrix.....	33
Table 9 – Environmental Risk Assessment and Management Plan.....	34
Table 10 – GIS DCP Rural Development Controls.....	40
Table 11 – GIS DCP Parking Controls.....	44

APPENDICES

- Appendix A – Design Plans
- Appendix B – Soil Investigation
- Appendix C – Groundwater Works Summary
- Appendix D – Protected Matters Search Tool (MNES)
- Appendix E – AHIMS Search
- Appendix F – Livestock Throughput Spreadsheet
- Appendix G – Water Quality Assessment
- Appendix H – Biosecurity Management Plan
- Appendix I – Heat Load Risk Assessment
- Appendix J – Traffic Impact Assessment
- Appendix K – Water & Nutrient Balance
- Appendix L – Emergency Management Plan
- Appendix M – Bushfire Protection Assessment

1 INTRODUCTION

Jardana Pty Ltd, (Jardana), is proposing the development of a 1,000 head feedlot (Stonehenge Feedlot) on Lot 1/DP7243, located on Pedlows Road, Stonehenge approximately 6 km south, southeast of the Glen Innes town centre. The feedlot has been designed as an opportunity feedlot which will be utilised to finish cattle when market conditions allow for it. As such, the feedlot may be empty when cattle are in short supply. The feedlot will be constructed with an initial capacity of 300 head with progressive expansion to 1,000 head as required.

The feedlot will be located in a controlled drainage area (CDA) which will ensure all clean, upslope water is diverted around the feedlot and all contaminated runoff from the feedlot is controlled and retained in a 1.1 ML sedimentation basin and an 8 ML effluent holding pond. The CDA and effluent holding pond will be constructed to the full capacity as part of the initial development. Effluent will be irrigated from the effluent holding pond as required to maintain the available capacity. Manure will be spread on-site.

The property is in the RU1 – Primary Production Zone and is permissible with consent from the Glen Innes Severn Council (GISC).

Refer to Appendix A for the proposed design plans.

The following industry documents are regularly referred to throughout this report. Links have been provided below for quick reference:

- [National Guidelines for Beef Cattle Feedlots in Australia 3rd Edition \(2012\)](#) (National Guidelines)
- [National Beef Cattle Feedlot Environmental Code of Practice 2nd Edition \(2012\)](#) (Code of Practice)
- [Beef Cattle Feedlots: Design and Construction \(2016\)](#) (Feedlot Design Manual)
- [Beef Cattle Feedlots: Waste Management and Utilisation \(2016\)](#) (Feedlot Waste Manual)
- [Technical Notes: Assessment and management of odour from stationary sources in NSW \(2006\)](#) (NSW S-Factor Guidelines)
- [Planning Guidelines – Intensive Livestock Agriculture Development \(2019\)](#) (Intensive Livestock Planning Guidelines)
- [Environmental Guidelines – Use of Effluent by Irrigation \(2003\)](#) (NSW Effluent Guidelines)

2 CONTEXT AND SETTING

2.1 SUBJECT SITE

The subject site, is located approximately 6 km south, southeast of the edge of Glen Innes and is accessed from the New England Highway via Stonehenge and Pedlows Roads (Figure 2). The property includes 16 separate land parcels with a total area of approximately 700 ha (Table 1). The feedlot site is located on Lot 1/DP7243 with the existing dwelling, feed storage and machinery sheds located on Lot 1/DP308507. The property is in the Glen Innes Severn Council (GISC) area and is zoned as RU1 – Primary Production. The property is currently utilised for cropping and grazing with some supplementary feeding.

Table 1 – Relevant Land Parcels

Lot/Plan	Area (ha)
1/DP180562	28.8
125/DP659979	56.7
1/DP1115100	14.4
2/DP1115100	53.2
3/DP1115100	24.4
1/DP7243	45.9
2/DP7243	65.2
3/DP7243	56.1
4/DP7243	58.8
5/DP7243	63.1
1/DP114064	1.1
1/DP308507	114
126/DP753311	43.4
22/DP753311	43.1
23/DP753311	29.9
4/DP114034	2.2
Total	700.3

2.2 CLIMATE

The climate of the region is temperate with rainfall distributed across the year with a slight summer dominance (Figure 1). Long-term rainfall statistics show a mean annual rainfall of 837 mm with a January average maximum temperature of 25.7 °C and a July average minimum temperature of 0.8 °C. Climate data is presented for Glen Innes, sourced from the Bureau of Meteorology (BOM).

Figure 1 –Climate Data

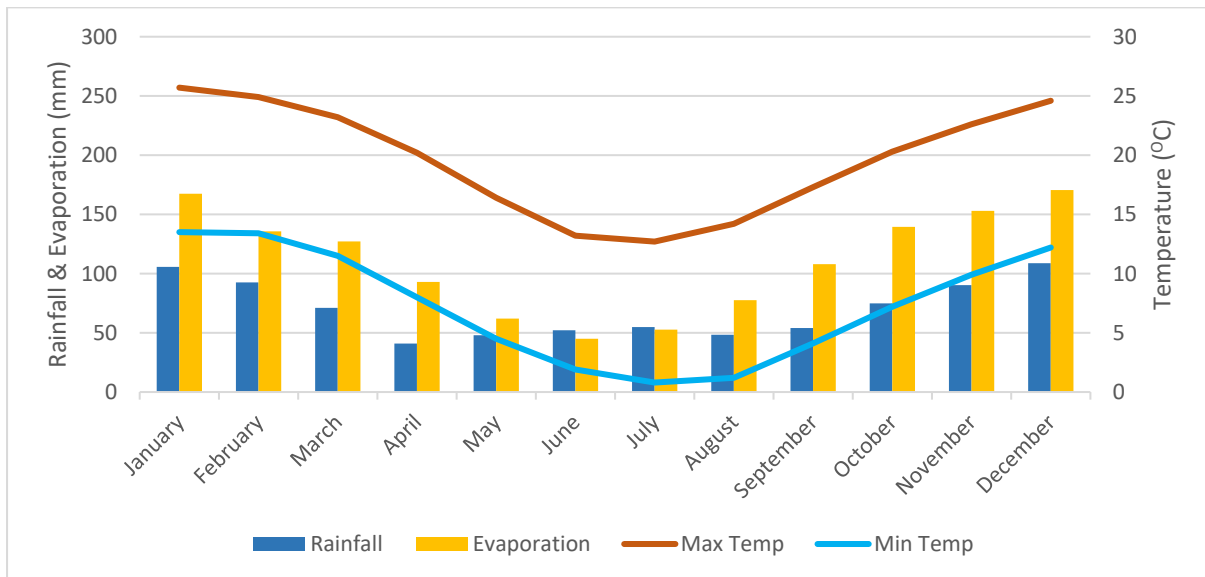

Document Path: C:\Users\greenwale\Documents\Ag_DSA\Projects\PED-001_Jardana Pty Ltd\Maps\PED-001_Figure 2 - Locality.mxd

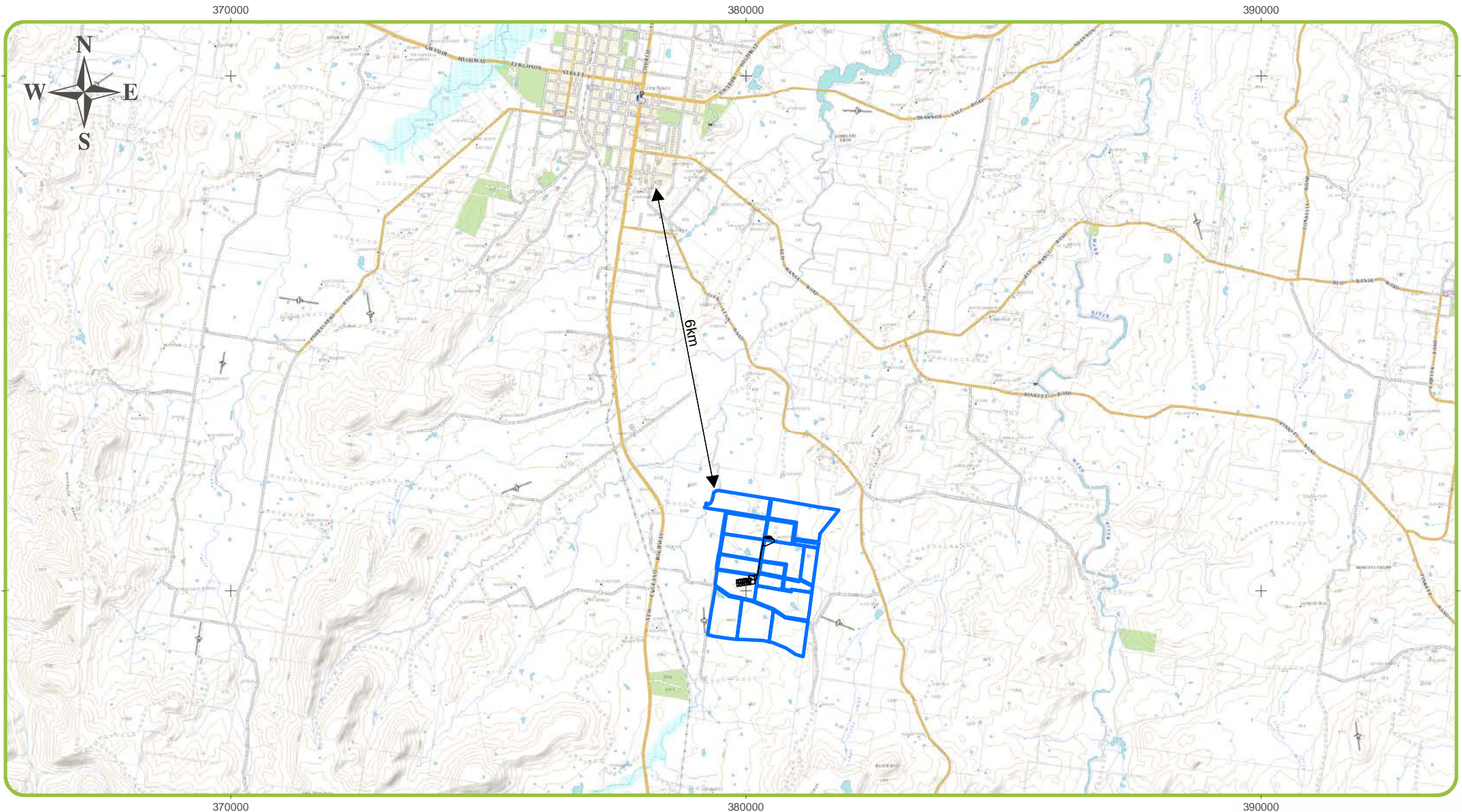

TITLE:

LOCALITY MAP

MAP NO: Figure 2

PROJECT: PED-001

LEGEND

- Proposed feedlot layout
- ▭ Property boundary

0 0.5 1 2 3 4 5
Kilometers

1:100,000

Coordinate System: GDA 1994 MGA Zone 56



Agricultural Development Services
Australia Pty Ltd (AgDSA)
ABN: 30 639 923 434

P: +61 418 446 245
E: matt.norton@agdsa.com.au

2.3 RECEPTORS AND SURROUNDING LAND USE

Sensitive receptors surrounding the proposed feedlot have been identified in Figure 3. Distances to the nearest of these receptors in each direction are identified in Table 2. The nearest sensitive receptor (R3) is approximately 1,230 m west, northwest of the proposed feedlot. R25 is a closer distance from the existing feed storage area (1,150 m) but this infrastructure is already existing and associated with the on-site grazing and supplementary feeding operations.

Generally, the region is dominated by cropping and grazing uses with some rural residential developments in the area. However, these developments are still zoned within the RU1 – Primary production zone with a minimum lot size of greater than 1 ha.

Table 2 – Sensitive Receptors

Receptor	Direction	Distance (m)	Nearest Infrastructure
R3	WNW	1,270	Feedlot
R23	W	1,540	Feed storage and machinery area
R25	N	1,150	Feed storage and machinery area
R26	NE	1,350	Feed storage and machinery area
R32	E	1,965	Feedlot Access Road
R38	SSE	1,905	Feedlot
R39	SSW	1,935	Feedlot
R44	SW	1,750	Feedlot

2.4 TOPOGRAPHY

The property is undulating with steeper land in the eastern part of the property with areas on the western side flattening out towards Beardy Waters (Figure 4). The highest point of the property is the southeast corner (1,170 m) and the lowest point of the property is in the northwest adjacent to Beardy Waters (1,070 m). The slope across the feedlot site is approximately 3 % in a northerly direction.

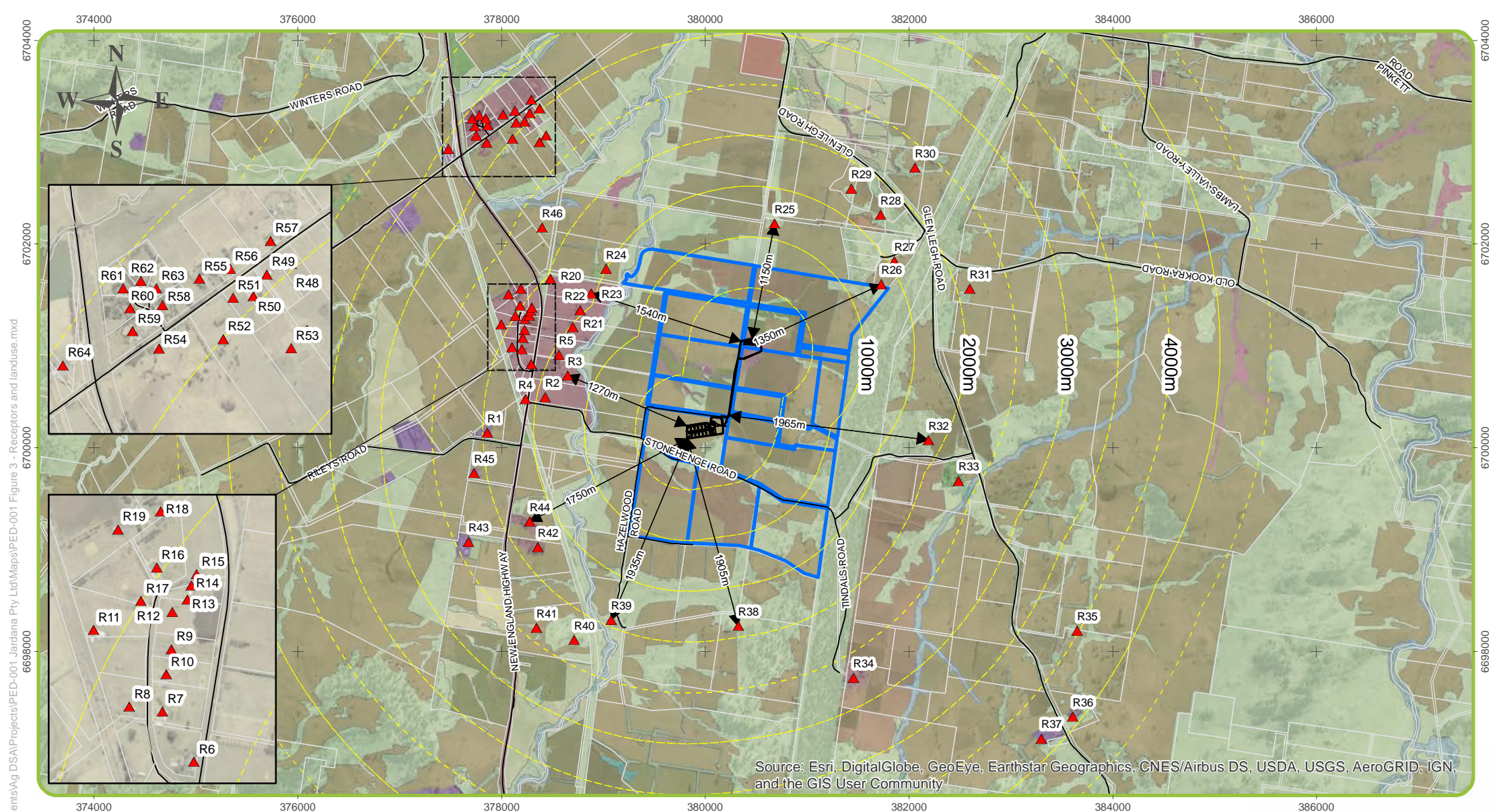

Source: Esri, DigitalGlobe, GeoEye, Earthstar Geographics, CNES/Airbus DS, USDA, USGS, AeroGRID, IGN, and the GIS User Community

TITLE:
SENSITIVE RECEPTORS AND LANDUSE

MAP NO: Figure 3

PROJECT: PED-001

0 0.5 1 2
 Kilometers

1:50,000

Coordinate System: GDA 1994 MGA Zone 56

LEGEND

▲ Sensitive receptors	2.1.0 Grazing native vegetation	5.4.2 Rural residential with agriculture
— Proposed feedlot layout	3.1.0 Plantation forests	5.4.3 Rural residential without agriculture
◆ Distance	3.2.0 Grazing modified pastures	5.5.0 Services
— Roads	3.2.1 Native/exotic pasture mosaic	5.7.0 Transport and communication
□ Property boundary	3.2.5 Sown grasses	5.7.2 Roads
□ Land parcels	3.3.0 Cropping	5.7.3 Railways
	3.3.3 Hay and silage	6.2.0 Reservoir/dam
	3.4.0 Perennial horticulture	6.3.0 River
	5.4.0 Residential and farm infrastructure	6.5.0 Marsh/wetland

Agricultural Development Services
 Australia Pty Ltd (AgDSA)
 ABN: 30 639 923 434

P: +61 418 446 245
 E: matt.norton@agdsa.com.au

Document Path: C:\Users\greenvalie\Documents\Ag_DSA\Projects\PED-001 Figure 3 - Receptors and landuse.mxd



Source: Esri, DigitalGlobe, GeoEye, Earthstar Geographics, CNES/Airbus DS, USDA, USGS, AeroGRID, IGN, and the GIS User Community

TITLE:
TOPOGRAPHY

MAP NO: Figure 4

PROJECT: PED-001

0 0.5 1
 ────┬───┬───┬───
 Kilometers

1:30,000

Coordinate System: GDA 1994 MGA Zone 56

LEGEND

- Proposed feedlot layout
- Roads
- Contours 1m (Lidar)
- Property boundary
- Land parcels



Agricultural Development Services
 Australia Pty Ltd (AgDSA)
 ABN: 30 639 923 434

P: +61 418 446 245
 E: matt.norton@agdsa.com.au

2.5 LAND AND SOIL

A Soil Investigation was completed by GeoLINK Environmental Management and Design (GeoLINK) which included an assessment of three soil sites indicative of the sites for the pens, effluent holding pond, and irrigation areas (Appendix B). This assessment generally identified a silty sand topsoil underlain by clay subsoils. The clay sub-soils have a low permeability which is suitable for clay liner construction.

2.5.1.1 Land and Soil Capability

Soils on the property are identified as Land and Soil Capability (LSC) Class 3, 4 and 6 (Table 3, Figure 5). Class 3 and 4 land is suitable for cropping and grazing with appropriate land management practices. Class 6 land is generally, highly limited for agricultural production. Satellite imagery indicates the presence of exposed granite in areas south of the feedlot site. This indicates shallow, rocky soils. LSC classes do not account for the suitability of the land to be used for intensive livestock activities such as the proposed feedlot and are focussed on more extensive livestock or plant production activities.

The feedlot site is mapped as LSC Class 6 land with the feedlot site being located on the lower slopes of this land. Current land management practices indicate this area is suitable for improved pastures. Regardless, the feedlot site has been suitably located on lower quality agricultural soils which minimises the fragmentation of agricultural soils (Photograph 1).

Table 3 – Land and Soil Capability

LSC Class	Definition
3	Land has moderate limitations and is capable of sustaining high-impact land uses, such as cropping with cultivation, using more intensive, readily available and widely accepted management practices. However, careful management of limitations is required for cropping and intensive grazing to avoid land and environmental degradation.
4	Moderate capability land: Land has moderate to high limitations for high-impact land uses. Will restrict land management options for regular high-impact land uses such as cropping, high-intensity grazing and horticulture. These limitations can be managed by specialised management practices.
6	Land has very high limitations for high-impact land uses. Land use is restricted to low-impact land uses such as grazing, forestry and nature conservation. Careful management of limitations is required to prevent severe land and environmental degradation.



Photograph 1 – Subject site showing transition of soil types

2.5.1.2 Acid Sulfate Soils

Acid sulfate soils (ASS) contain high levels of iron sulfide minerals, generally in anaerobic conditions. ASS are typically found in low lying coastal areas and, if disturbed, they can cause damage to both the built and natural environment. The site is not mapped as high or low probability of ASS occurring (Figure 5) and, given the inland location and elevation, are extremely unlikely to occur.

2.5.1.3 Contaminated Land

The property is not listed on the EPA list of notified contaminated sites. However, the property has a long history of agricultural use including livestock activities and cropping. These activities require the ongoing use of a range of chemicals. However, the land on which development is proposed has only been subject to cropping and the associated chemical applications. These activities are standard practice on farming land. The historical chemical use will not have an impact on the feedlot.

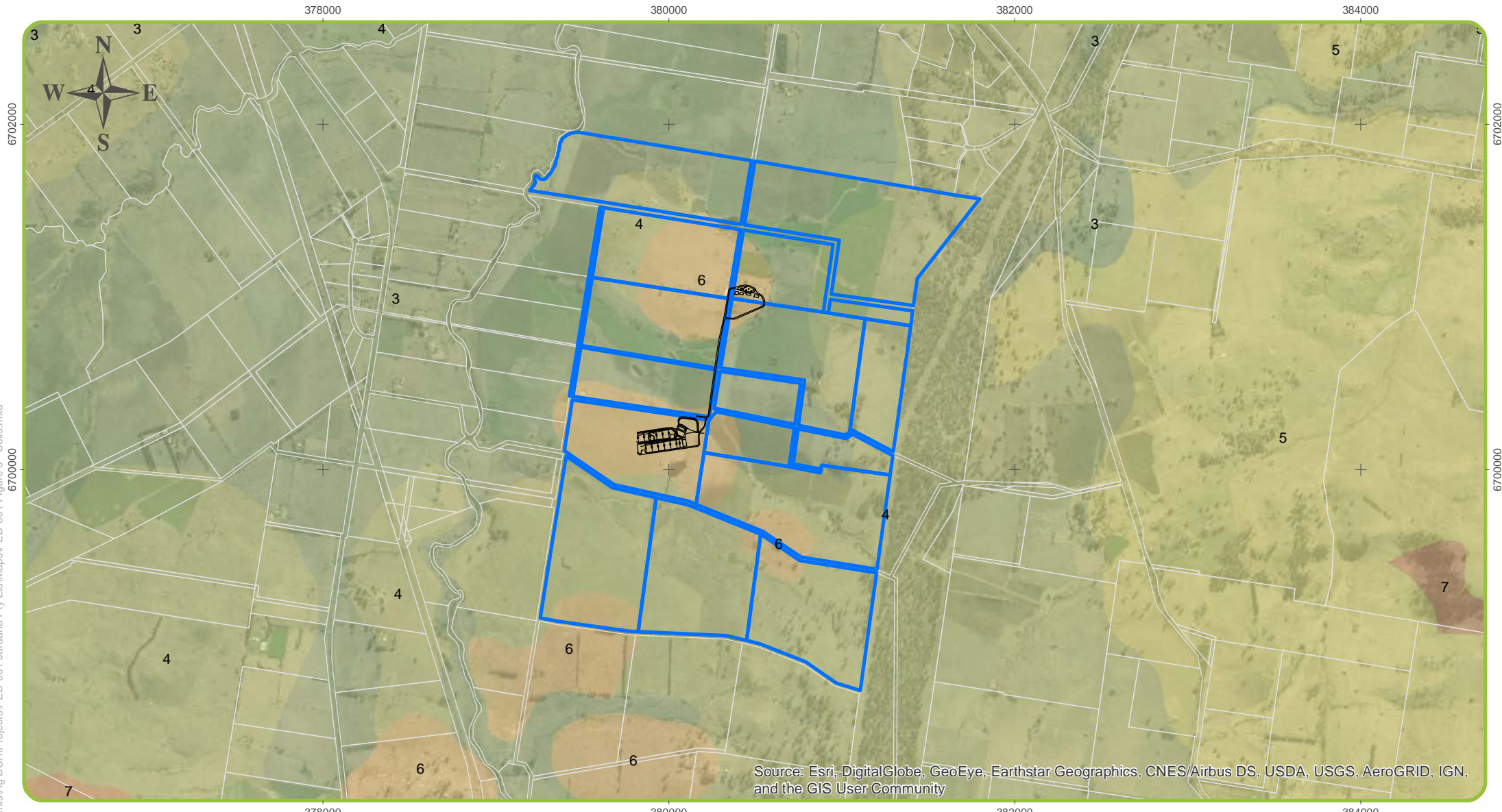

TITLE:
SOILS AND LAND SUITABILITY

MAP NO: Figure 5

PROJECT: PED-001

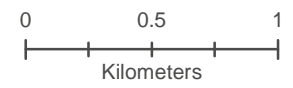

1:30,000

Coordinate System: GDA 1994 MGA Zone 56

LEGEND

- | | | | |
|---|------------------------------|--|--------------------|
| — | Proposed feedlot layout | | Land suitability 3 |
| | Property boundary | | 4 |
| | Land parcels | | 5 |
| | Acid sulphate soils risk map | | 6 |
| | | | 7 |



Agricultural Development Services
 Australia Pty Ltd (AgDSA)
 ABN: 30 639 923 434

P: +61 418 446 245
 E: matt.norton@agdsa.com.au

Date: 15/10/2020

Data Source: DCDB, September 2020, © Spatial Services | Department of Finance, Services and Innovation
 Land and Soil Capability Mapping for NSW, © State Government of NSW and Department of Planning, Industry and Environment 2013
 Acid Sulphate Soil Risk Map, © State Government of NSW and Department of Planning, Industry and Environment 1998

Document Path: C:\Users\greenvale\Documents\Ag_DSA\Projects\PED-001_Jardana Pty Ltd\Maps\PED-001_Figure 5 - Soils.mxd

2.6 SURFACE WATER

2.6.1 FISHERIES MANAGEMENT ACT 1994

Beardy Waters is mapped as a key fish habitat under the *Fisheries Management Act 1994*. However, it is not identified as containing threatened freshwater fish on the freshwater threatened species distribution maps.

2.6.2 DRAINAGE FEATURES

There are several low-order drainage features across the property (Figure 6). Generally, the property drains from east to west where drainage features converge with Beardy Waters which is part of the Macintyre River catchment and Murray-Darling Basin. These drainage features are spring-fed which results in regular flows which are captured by the 11 existing on-site water storages.

The total volume of all the existing storages on the property is 42 ML with the property having a maximum harvestable right dam capacity of 53 ML. Under the Harvestable Rights Order, this water can be used for intensive livestock activities.

2.6.3 GLEN INNES DRINKING WATER CATCHMENT

The property is located within the drinking water catchment for Glen Innes. The *Glen Innes Integrated Water Cycle Management: Part 2 Strategy Plan (2009)* discusses the issue of raw water quality being impacted by rural activities. It states that the impact on raw water quality by rural activities is not a concern as the water treatment plant is designed to deal with contaminants in the raw water.

Regardless, the sensitivity of the receiving surface water values needs to be considered in the design of the feedlot and sizing of the effluent holding pond.

2.7 GROUNDWATER

There are no groundwater bores mapped on the property with the nearest bore, GW965621, located on the adjacent property to the north (Figure 7). However, as this bore is located in a similar topographical landscape, it is considered appropriate to represent the groundwater conditions of the subject site.

The groundwater works summary (Appendix C) identifies that the bore was drilled to a depth of 33 m through a layer of clay and various layers of basalt. The clay layer extended to a depth of 3 m. The shallowest water-bearing zone is approximately 10 m deep.

Document Path: C:\Users\greenvalle\Documents\Ag_DSA\Projects\PED-001_Jardana Pty Ltd\Maps\PED-001_Figure 6 - Surface water features.mxd

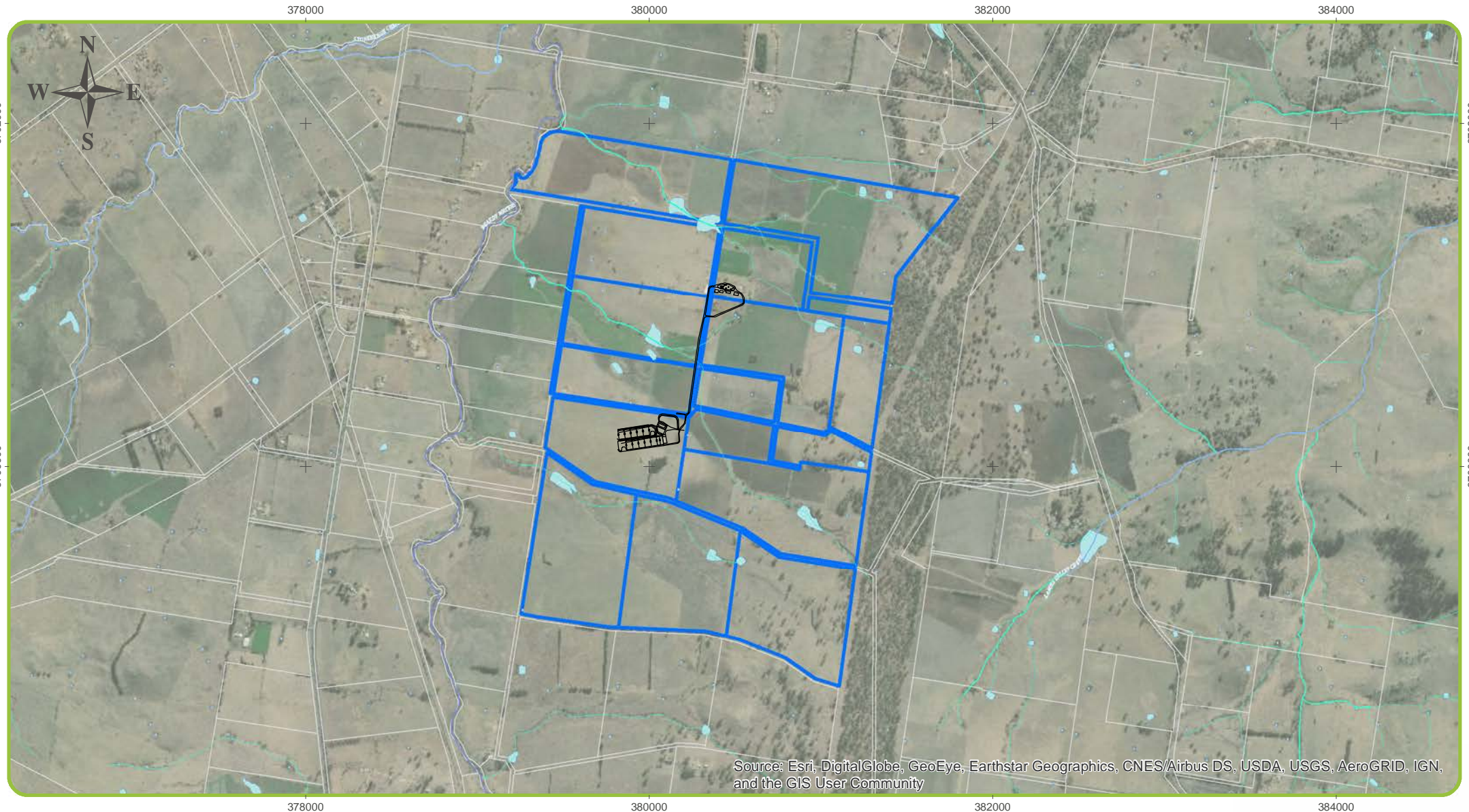

Source: Esri, DigitalGlobe, GeoEye, Earthstar Geographics, CNES/Airbus DS, USDA, USGS, AeroGRID, IGN, and the GIS User Community

TITLE:
SURFACE WATER FEATURES

MAP NO: Figure 6

PROJECT: PED-001

0 0.5 1
 Kilometers

1:30,000

Coordinate System: GDA 1994 MGA Zone 56

LEGEND

—	Proposed feedlot layout	Hydro line relevance	— 7	▭	Property boundary
▪	Waterfalls_springs	— 1; 2; 3; 4	— 8	▭	Land parcels
▪	Bores	— 5	— 9		
▭	HydroArea	— 6	— 10		

AgDSA

Agricultural Development Services
 Australia Pty Ltd (AgDSA)
 ABN: 30 639 923 434

P: +61 418 446 245
 E: matt.norton@agdsa.com.au

Date: 15/10/2020

Data Source: DCDB, September 2020, © Spatial Services | Department of Finance, Services and Innovation
 NSW Hydrography, September 2020, © Department of Finance, Services and Innovation

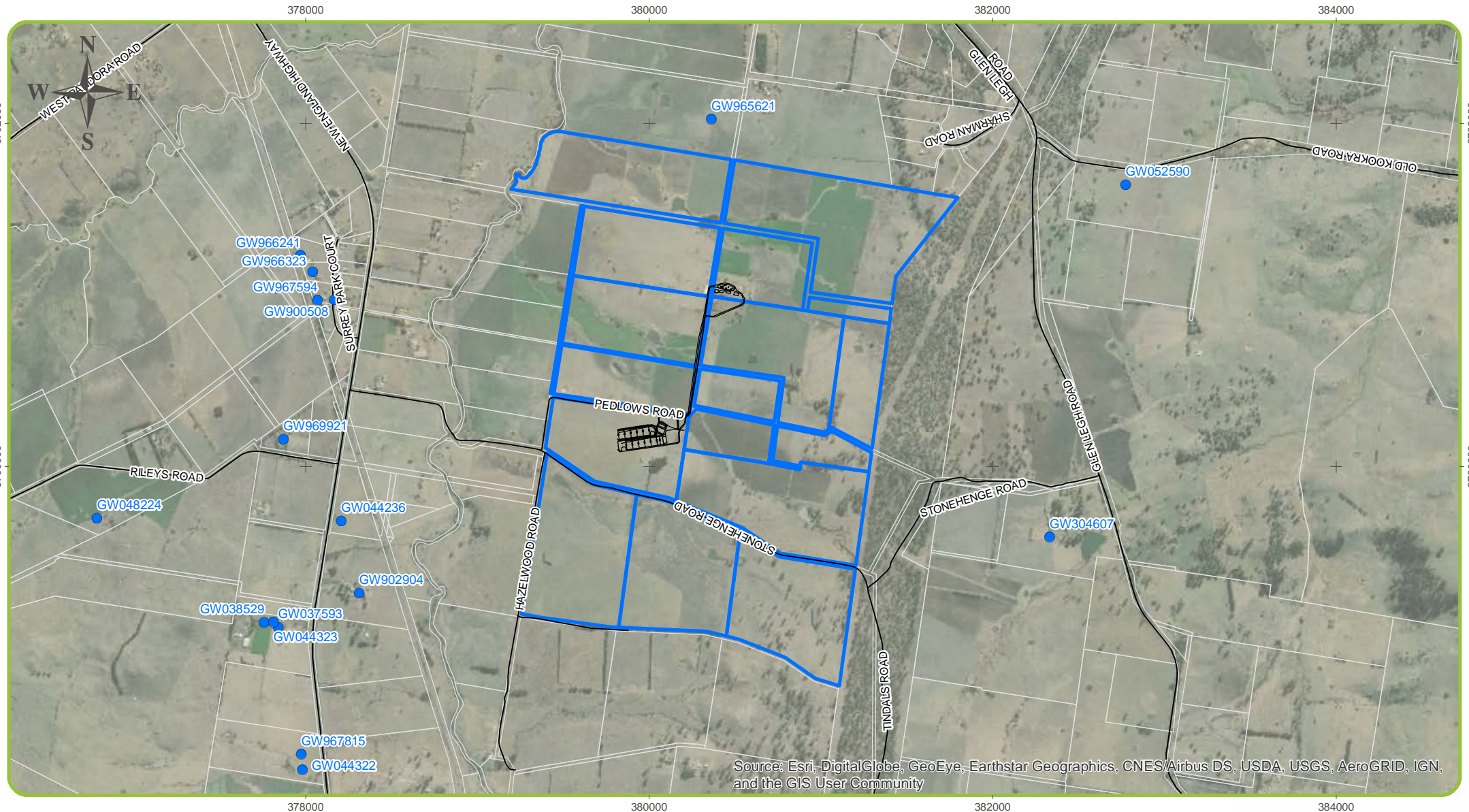

Source: Esri, DigitalGlobe, GeoEye, Earthstar Geographics, CNES/Airbus DS, USDA, USGS, AeroGRID, IGN, and the GIS User Community

TITLE:
GROUNDWATER BORES

MAP NO: Figure 7

PROJECT: PED-001

0 0.5 1
 Kilometers

1:30,000

Coordinate System: GDA 1994 MGA Zone 56

LEGEND

- Groundwater bore
- Proposed feedlot layout
- Roads
- Property boundary
- Land parcels



Agricultural Development Services
 Australia Pty Ltd (AgDSA)
 ABN: 30 639 923 434

P: +61 418 446 245
 E: matt.norton@agdsa.com.au

2.8 FLORA AND FAUNA

There are pockets of native vegetation across the property. However, the landscape has been significantly modified to allow for the existing cropping and grazing activities. Given the historic cropping use of the development site, cleared areas are unlikely to provide habitat for fauna.

2.8.1.1 *Biodiversity Conservation Act 2016*

There are various small pockets of native vegetation regulated under the *Biodiversity Conservation Act 2016* (BC Act) across the property (Figure 8). Much of this vegetation is located on the eastern edge of the property. The feedlot site and proposed irrigation areas are not mapped as containing any native vegetation regulated under the BC Act. The feedlot site is within existing cropping and grazing land with no clearing of native trees required for the proposed development. All effluent irrigation areas are generally downslope of on-site native vegetation.

2.8.1.2 *Local Land Services Act 2013*

The entire property is mapped as Category 1 – exempt land with no further clearing permits required from Local Land Services. The nearest Category 2 land is associated with Beardy Waters (Figure 8).

2.8.2 ENVIRONMENTAL PROTECTION AND BIODIVERSITY CONSERVATION ACT 1999

The Protected Matters Search Tool (PMST) was used to identify any Matters of National Environmental Significance (MNES) within 5 km of the proposed site (Appendix D). MNES are protected under the *Environmental Protection and Biodiversity Conservation Act 1999* (EPBC Act). The search identified four threatened ecological communities, 34 threatened species and 11 migratory species. As the feedlot is proposed on existing farming land which has been subject to extensive historical clearing, no clearing of native vegetation will be required. As such, an EPBC referral is not required.

2.9 WETLANDS

As all water bodies on the property are constructed stock dams with no adjacent native vegetation, they are not considered to be natural wetlands.

2.9.1 ENVIRONMENTAL PROTECTION AND BIODIVERSITY CONSERVATION ACT 1999

Wetlands of international importance, listed under the Ramsar Convention, are a matter of National Environmental Significance (MNES) under the EPBC Act. The site is located over 1,000 km from the nearest downstream Ramsar wetland (Appendix D).

Document Path: C:\Users\greenvalle\Documents\Ag_DSA\Projects\PED-001_Jardana Pty Ltd\Maps\PED-001_Figure 8 - Native vegetation map.mxd

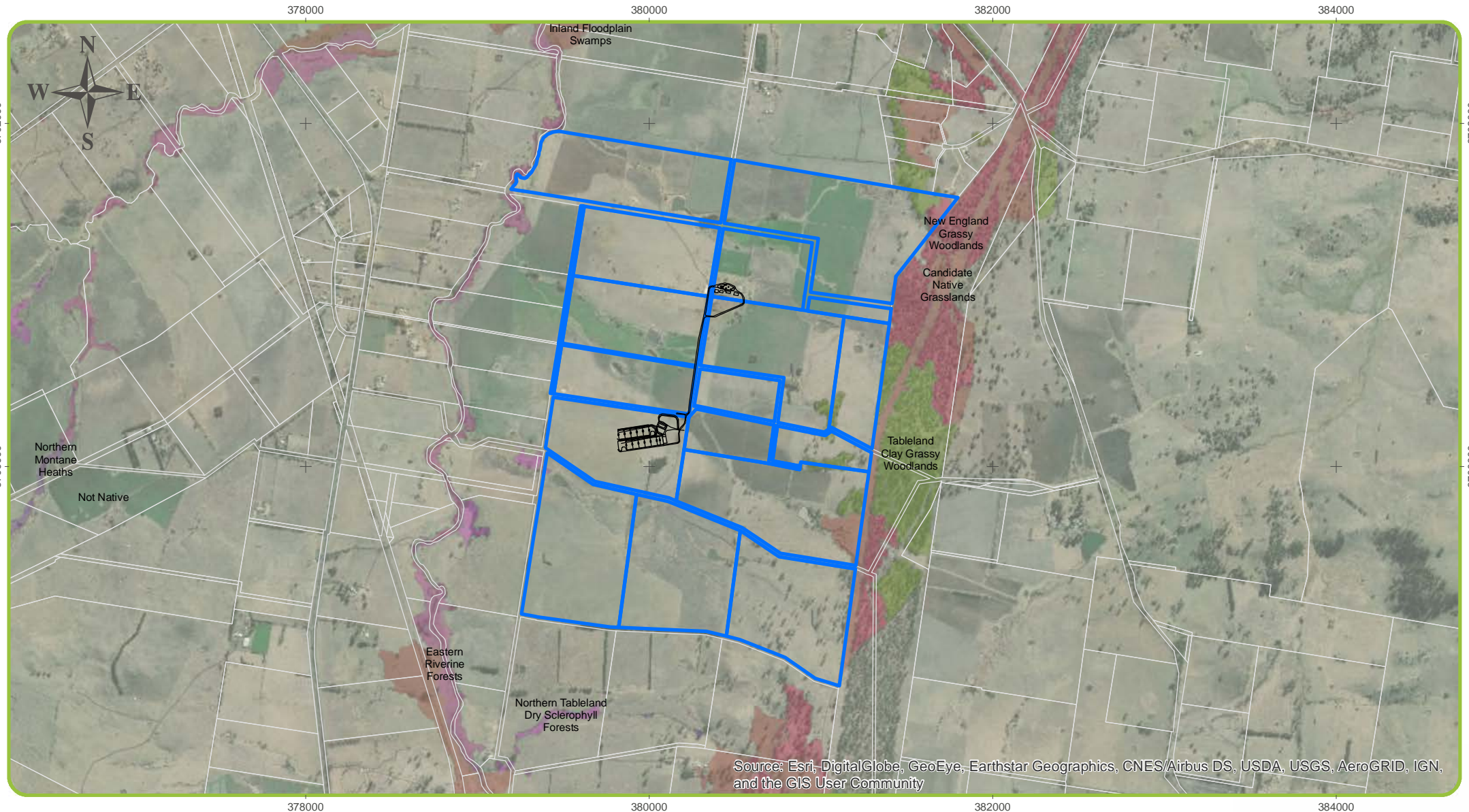

Source: Esri, DigitalGlobe, GeoEye, Earthstar Geographics, CNES/Airbus DS, USDA, USGS, AeroGRID, IGN, and the GIS User Community

TITLE:

NATIVE VEGETATION MAP

MAP NO: Figure 8

PROJECT: PED-001

0 0.5 1
Kilometers

1:30,000

Coordinate System: GDA 1994 MGA Zone 56

LEGEND

- Proposed feedlot layout
- Property boundary
- Land parcels

Vegetation class PCT 4467

- Candidate Native Grasslands
- Eastern Riverine Forests
- Inland Floodplain Swamps
- New England Grassy Woodlands
- Northern Montane Heaths
- Northern Tableland Dry Sclerophyll Forests
- Not Native
- Tableland Clay Grassy Woodlands

AgDSA

Agricultural Development Services
Australia Pty Ltd (AgDSA)
ABN: 30 639 923 434

P: +61 418 446 245
E: matt.norton@agdsa.com.au

Date: 15/10/2020

Data Source: DCDB, September 2020, © Spatial Services | Department of Finance, Services and Innovation
State Vegetation Type Map: Border Rivers Gwydir / Namoi Region Version 2.0., © State Government of NSW and Department of Planning, Industry and Environment 2015

2.10 CULTURAL HERITAGE

As the proposed development will disturb the ground surface, the due diligence process outlined in the *Due Diligence Code of Practice for the Protection of Aboriginal Objects in New South Wales* (Cultural Heritage Guidelines) was completed. This included a search of the Aboriginal Heritage and Information Management System, (AHIMS) for Lot 1/DP7243 which includes the feedlot site (Appendix E). The generic due diligence assessment involves five steps which are addressed below:

1. Will the activity disturb the ground surface?

As the feedlot construction will require the formation of a uniform pen surface and effluent containment system, it will result in significant ground disturbance.

2. Desktop assessment:
 - a. Are there any confirmed site records or landscape features on AHIMS?

A search of AHIMS (Appendix E) did not identify any Aboriginal sites or places on or near the development site. No other sources of information are available.

- b. Are there any landscape features that indicate the presence of Aboriginal objects?

As the land is defined as 'disturbed land' which has been subject to extensive historical clearing and cultivation, it is reasonable to conclude that there are no known Aboriginal objects or a low probability of objects occurring in the area. As such, under the Cultural Heritage Guidelines, the development can proceed without a detailed Aboriginal Cultural Heritage Assessment (ACHA) or Aboriginal Heritage Impact Permit (AHIP).

3 PROPOSED DEVELOPMENT

3.1 OVERVIEW

The 1,000 head proposed feedlot has been designed as an opportunity feedlot which will be utilised to finish cattle when market conditions allow for it. As such, the feedlot may be empty when cattle are in short supply. The feedlot design has been completed with consideration for 1,000 standard cattle units (SCU). However, with pen cleaning and cattle movements, combined with market considerations, the feedlot will never stock more than 1,000 head at a time. The feedlot will be constructed with an initial capacity of 300 head with progressive expansion to 1,000 head as required. The CDA and effluent holding pond will be constructed to the full capacity as part of the initial development.

At the full capacity, the feedlot will require an average of three B-doubles per week. Temporary construction traffic will be a similar number of smaller vehicles.

The proposed feedlot has been designed in accordance with the National Guidelines and the Code of Practice. Refer to Appendix A for design plans.

3.1.1 FEEDLOT DESIGN

The feedlot will have a stocking density of 18 m²/SCU with 10 pens with dimensions of 36 m (width) by 50 m (depth) resulting in an individual pen area of 1,800 m². Each pen will have a maximum capacity of 100 SCU with pens constructed in two rows, each with separate cattle lanes and drains. Two additional hospital pens will be constructed at the eastern end of the southern row adjacent to a new handling facility. As these pens will only contain cattle previously held in the feedlot pens, the capacity of these two pens has not been considered as production capacity.

The pens will have a uniform downslope of between 2.5 % and 4.0 % which facilitates pen drainage and minimises pen to pen drainage. A downslope range is provided as the final slope will depend on earthworks optimisation. Each drain will have a slope between 0.5 % and 1.0 % which will minimise sediment deposition in the drains. As with the pen slope, this range has been provided to allow for flexibility for earthworks optimisation.

The feedlot will be located in a controlled drainage area (CDA) which will ensure all clean, upslope water is diverted around the feedlot and all contaminated runoff from the feedlot controlled and contained in a 1.1 ML sedimentation basin and an 8 ML effluent holding pond.

The pen width will result in a feed bunk allowance of 360 mm/SCU which is within the range identified in the Feedlot Design Manual. The feed bunks will be made of pre-cast concrete with a concrete apron extending 3 m into the pen. Water troughs will be constructed along the fence lines towards the bottom of the pens. Each production pen will be serviced by two water troughs, each with a concrete apron extending 3 m into the pens.

A manure pad will be located between the pens and the sedimentation basin which will be used for composting mortalities and temporarily stockpiling manure prior to spreading. The manure pad will be located within the CDA.

3.1.2 OPERATIONAL DETAILS

3.1.2.1 *Life of Operation*

The feedlot has been designed for long-term sustainability and has an indefinite lifetime. However, as it is an opportunity feedlot, it may remain empty for long periods. There is adequate agricultural land to ensure effluent irrigation and manure spreading can occur sustainably.

Should the feedlot be decommissioned, infrastructure not required for the ongoing operation of the property will be removed and all effluent and manure applied to paddocks. The sedimentation basin and effluent holding pond will be filled in and the site returned to pasture.

3.1.2.2 *Employment*

The proposed feedlot will generally be operated by the property owner and family. At full capacity, one further employee may be required on a casual or part-time basis. The proposed development will also result in other indirect jobs (contractors, drivers, tradespeople, etc.). Six people will be employed across the construction phase.

3.1.2.3 *Hours of Operation*

Due to welfare requirements, staff and general operations may be required 24-hours a day, seven-days a week. However, where possible, operations and work will, generally, be restricted to daylight hours between 6 am and 5 pm. External heavy-vehicle movements will only occur between 9 am and 2.30 pm to avoid peak and school hours.

3.1.3 LIVESTOCK THROUGHPUT

The feedlot will target the 100-day grain-fed accreditation under the National Feedlot Accreditation Scheme (NFAS). On average, cattle will enter the feedlot at 380 kg and exit the feedlot at 520 kg with an average daily gain of 1.4 kg. With an average weight of 450 kg, this results in an equivalent of 0.81 SCU per head. The average occupancy of the feedlot is assumed at 80 % which is based on industry averages.

A feedlot of this size generally has a mortality of approximately 1 % which, with an annual throughput of 3,623 head results in approximately 36 mortalities per year. As such, the outgoing cattle have been estimated at 3,587 head/year. Approximately 1,780 head of cattle can be produced on the site or would normally be grazed on the property. Livestock throughput has been calculated in Appendix F.

3.1.4 FEED REQUIREMENTS AND STORAGE

An as-fed intake of 12 kg/day has been assumed with the ration consisting of grain, roughage, and supplements. This results in an annual as-fed feed requirement of approximately 4,350 tonnes. Based on historical yields, approximately 900 tonnes of grain and 3,500 tonnes of silage can be produced on-site. This equates to approximately 25 % of the feedlot grain requirements and over 100 % of the silage requirements. All grain will be stored in silos or the proposed commodity shed with baled silage stored adjacent to these ancillary buildings as per the existing operations. Grain will be processed using a grain roaster.

3.1.5 WATER SUPPLY

According to the National Guidelines, approximately 24 ML/year of water is required per 1,000 head. However, a study by Davis, Wiedemann and Watts (2008) identified that, based on data from operating feedlots, the water use for feedlots is closer to 17 ML/1,000 head. As such, it is conservatively assumed that 20 ML/year of water is required per 1,000 head of capacity.

The property has 11 existing dams which have a combined volume of 42 ML (Section 2.6.1). As these dams are spring-fed, their reliability is much greater than a dam completely reliant on rainfall and overland flow. In fact, they have not dried up over the recent, severe drought period. As such, they will be capable of supply water to the proposed feedlot.

An assessment of water quality was completed by Environmental Analysis Laboratory (Appendix G). Samples of water were obtained from an on-site dam, Beardy Waters and an on-site bore.

3.1.6 ELECTRICITY SUPPLY

There is an existing electricity supply at the site of the dwelling and machinery sheds. The feedlot will not require any further electricity except for the occasional use of portable generators for maintenance activities.

3.1.7 ANIMAL WELFARE AND BIOSECURITY

In accordance with the *Australian Animal Welfare Standard and Guidelines for Cattle 2016* (animal welfare code), the proposed feedlot has been designed with best practice animal welfare standards. The proposed feedlot will be operated in accordance with the animal welfare code.

If a mass death event occurs, under guidance from officers from GISC and DPI along with consulting veterinarians, a suitable location and disposal method will be identified. A preliminary location has been identified adjacent to the feedlot.

A farm biosecurity plan and emergency animal disease action plan has been prepared for the proposed feedlot (Appendix H). A heat load risk assessment has also been completed (Appendix I). This identified that, given the temperate Glen Innes climate, shade is not required for the feedlot. With cool, wet winters, shade can sometimes be detrimental to the pen surface, cleaning practices and subsequent odour control. However, the need for shade will be reassessed annually and constructed should it provide for a better animal welfare outcome.

3.1.8 CONSTRUCTION

Initially, the feedlot will be constructed to accommodate a total of 300 SCU within three pens. At least one of the hospital/handling pens will also be constructed. The external embankments of the CDA and the full sedimentation basin and effluent holding pond will be constructed with the first three pens. Excess overland flow not required for the final feedlot CDA will be excluded from the effluent holding pond.

3.1.8.1 *Erosion and Sediment Control*

The material excavated from the effluent holding pond will be utilised as fill material as required throughout the rest of the feedlot. As such, all runoff from the construction site will be contained within the effluent pond where sediment will be allowed to settle. Additionally, there are various on-site dams downstream of the feedlot site which will provide further sediment control prior to surface water leaving the property. Areas disturbed during construction, which are not located within a hardstand area, will be rehabilitated to encourage grass cover. Any additional topsoil removed from the feedlot site will be stockpiled adjacent to the feedlot which will provide a visual barrier. Any topsoil not required for the revegetation of disturbed areas will remain in this stockpile which will also be revegetated.

3.2 TRAFFIC

3.2.1 TRAFFIC GENERATION

The feedlot is accessed from the New England Highway via Stonehenge and Pedlows Roads. Pedlows Road is the lowest order road available to the property and does not provide access to any other properties. A new property access from Pedlow Road will be utilised for the feedlot. It is anticipated that the largest trucks accessing the feedlot will be 19 m B-doubles.

Heavy-vehicles will be required to transport cattle to and from the feedlot as well as feed and commodities into the feedlot. Some cattle are produced on the property or are grazed on-site prior to entering the feedlot. These cattle would be trucked to the site regardless of the feedlot development and have not been considered for truck generation. As all manure will be utilised on-site, no manure transport will occur. Commodities grown on-site (grain and silage) have also been excluded from truck generation.

There will be negligible light-vehicle movements associated with the feedlot development beyond the light-vehicle movements associated with the existing dwelling and rural operations. Heavy-vehicle movements have been estimated in Appendix F and summarised in Table 4. A Traffic Impact Assessment has been prepared by Apex Engineers (Appendix J).

Table 4 – Traffic

		Proposed Feedlot
Incoming Cattle		
Cattle (head/year)		1,843
Typical Truck Type		B-double
Capacity (head/truck)		80
Trucks (vehicles/year)		23
Outgoing Cattle		
Cattle (head/year)		3,587
Typical Truck Type		B-double
Truck Capacity (head)		60
Trucks (vehicles/year)		60
Feedstuffs		
Feed imported (tonnes/year)		2,752
Typical Truck Type		B-double
Truck Capacity (tonnes)		36
Trucks (vehicles/year)		76
Outgoing Manure		
Manure exported (tonnes)		0
Typical Truck Type		-
Capacity (tonnes)		-
Trucks (vehicles/year)		0
Total Trucks	Yearly	159
	Weekly	3

3.2.2 PARKING

Heavy-vehicle parking is provided in the open space adjacent to the existing machinery and proposed commodities sheds and cattle handling facilities. There are additional parking areas adjacent to the on-site dwelling and feedlot. There will be no requirement for heavy-vehicles to park in the Pedlows Road corridor.

3.2.3 INTERNAL ROAD DESIGN

The existing internal roads have been constructed with gravel/crushed rock and will be, as required, upgraded, and/or maintained, to ensure all-weather access.

3.3 CONTROLLED DRAINAGE AREA & STORMWATER MANAGEMENT

3.3.1 STORMWATER MANAGEMENT

As the development is rural in nature, industry-specific stormwater controls identified in the National Guidelines have been incorporated into the design. This includes the construction of a CDA to exclude clean upslope runoff and to control and contain stormwater contaminated by the feedlot. As much as reasonably possible, the soft catchment areas within the CDA have been reduced to minimise incidental take of clean overland flow which would otherwise enter the natural drainage network to supply downstream users.

In feedlots, effluent generation is generally rainfall dependent. Large, regular volumes of effluent are not generated each day. Small volumes may be generated regularly from the cleaning of water troughs. This means the biological treatment of feedlot effluent, using a wastewater treatment plant, is generally not effective. Industry-specific effluent controls, including a sedimentation basin with a drop-board weir, an effluent holding pond, and sustainable irrigation of effluent, will be implemented.

Refer to Table 5 for a summary of the feedlot catchment areas, maximum drain length, sedimentation basin area and volume, and the area and volume of the effluent holding pond. The feedlot CDA is a standard design for a small feedlot.

Table 5 – Controlled Drainage Area

Pen Area (ha)		1.8
Hard Catchment Area (ha)		1.5
Soft Catchment Area (ha)		0.4
Drain Length (m)		280
Sedimentation Basin	Area (ha)	0.125
	Volume (ML)	1.1
Effluent Holding Pond	Area (ha)	0.535
	Volume (ML)	8.0

3.3.2 SURFACE PREPARATION

Any surfaces in the CDA that effluent or manure is either deposited on, transferred in, or stored, must be constructed to ensure a low permeability surface. These areas include pens, drains, manure pad, sedimentation basin and effluent holding pond. The National Guidelines require a maximum permeability of 1×10^{-9} m/s which is the equivalent of 0.1 mm/day. This low permeability is usually achieved by the construction of a clay liner. Areas which are subject to regular traffic, both machinery and cattle, will include a mixture of gravel/rock and clay to achieve a stronger surface which is less susceptible to damage. The sedimentation basin and effluent holding pond, which will be subject to occasional traffic during cleaning, will be constructed with clay.

Based on the Soil Investigation (Appendix B), the sub-soils are suitable for the construction of this clay liner.

3.3.3 DRAINS

Drains will be constructed at the bottom of each row. These drains will control runoff from the pens and direct it into the sedimentation basin. Each drain will have 3 m wide base with a 1 m batter on either side and have a slight slope (between 0.5 % and 1.0 %) which may vary slightly subject to topography and detailed design. Drains must be sized to convey rainfall from a design storm having a minimum average recurrence interval (ARI) of 20 years. However, construction equipment and processes used to build these drains, generally result in them being built to handle a larger flow. The proposed drainage system has been designed in accordance with the National Guidelines.

3.3.4 SEDIMENTATION BASIN

As effluent drains off the pens and manure pad, it can contain a high level of solids (manure) which can be readily removed by a simple sedimentation basin with a spaced drop-board weir (Typical Effluent Management System Section, Appendix A). Drop-board weirs are preferred as the boards can be removed to facilitate the cleaning of the weir. The sedimentation basin will be shallow (depth of less than 1 m) with a slight (0.1 %) slope towards the weir. This slows effluent and facilitates the settling of solids. It also allows for the solids to be quickly dried prior to removal. The sedimentation weir will include a 500 mm freeboard on the concrete block wall.

In accordance with the National Guidelines, the proposed sedimentation basin has been designed to cater for the peak flow of a design storm having an ARI of 20 years (Table 6). The proposed sedimentation basin will have a volume of 1.1 ML. This assumes runoff co-efficient of 0.8 for any hardstand areas including pens, drains and the manure pad, and 0.4 for any grassed soft catchment areas (Table 5). The tabulated rainfall intensity data was sourced from the Bureau of Meteorology (BOM) Rainfall IFD Data System. The conservative final size of the sedimentation basin is to maximise sedimentation accumulation during longer wet periods when sediment is consistently not dry enough to be removed (e.g. wet winter).

Table 6 – Sedimentation Basin Design

Parameter	Proposed Feedlot
System Type	Basin
Length to Width Ratio	2.0
Scaling Factor	2.5
Max Design Flow Velocity (m/s)	0.005
Pen Overland Flow Length (m)	50
Max. Drain Length (m)	280
Drain Flow Time (min)	6.67
Time of Concentration (min)	14.48
ARI 20 Rainfall Intensity (mm/hr)	110
ARI 20 Peak in Flow Rate (m ³ /s)	0.9
Required Volume (ML)	0.912
Proposed Volume (ML)	1.1

3.3.5 EFFLUENT HOLDING POND

The sedimentation basin will remove most of the solids from the effluent stream. However, the remaining effluent will still contain a high level of contaminants, mainly nutrients and salt. As such, this effluent needs to be controlled to prevent it regularly entering the natural drainage system. According to the NSW Effluent Guidelines, an effluent holding pond must be designed to capture effluent from the CDA in a 90th percentile wet year. The proposed volume of the effluent holding pond complies with this requirement. A water balance has been completed to determine the required volume of 8 ML (Appendix K). Due to the significant amount of data, only a portion of this water balance has been attached. The AgDSA developed Microsoft Excel model can be provided upon request. However, this model remains the intellectual property of AgDSA.

Subject to earthworks requirements, the constructed volume of the effluent holding pond will meet or exceed this volume. As the containment of water within the effluent holding pond is required for environmental protection, its volume is exempt from consideration under the maximum harvestable rights dam calculation for the property.

If the depth of the effluent holding pond exceeds the clay layer identified in Section 2.5 and 2.7, this clay material will be stockpiled, replaced and compacted to ensure the base of the effluent holding pond achieved the maximum permeability of 1×10^{-9} m/s. Any basalt material excavated to form the effluent holding pond will likely be used as construction material for trafficable surfaces.

3.3.6 EFFLUENT IRRIGATION

Water contained in the effluent holding pond will then either be reused for dust suppression on internal roadways or sustainably irrigated to surrounding agricultural land. The design of the CDA has minimised effluent generation by minimising the catchment area as much as reasonably possible. The application of effluent to agricultural land is the most suitable option for release as sewerage infrastructure is not available at the site. A total of approximately 55 ha of effluent irrigation area has been identified (Property Plan, Appendix A). A nutrient mass balance has been undertaken which identified that the available area exceeds the minimum area required for the long-term management of soil Phosphorous and Nitrogen levels (Appendix K).

3.3.7 MANURE MANAGEMENT

A manure handling area will be located between the feedlot pens and the sedimentation basin. Manure will be temporarily stockpiled in this area prior to utilisation on-site. A total of 115 ha of manure spreading area is available on the property (Property Plan, Appendix A). This is likely to be adequate to allow for all manure produced by the feedlot to be utilised on-site. Any excess manure not required for on-site spreading can be removed to off-site locations for utilisation. The use of feedlot manure for fertiliser is standard agricultural practice and can significantly improve soil conditions.

3.4 SITE SUITABILITY

3.4.1 COMMUNITY AMENITY

As described in the National Guidelines, the S-Factor methodology has been used to determine the required separation distance for the proposed feedlot (Table 7). All receptors comply with the required separation distance. The National Guidelines S-Factor assessment is the equivalent of a Class 1 feedlot under the NSW S-Factor Guidelines. With a stocking density of 18 m²/SCU and a maximum pen cleaning interval of 13 weeks, the proposed feedlot is considered a Class 1 feedlot. Even if the feedlot were managed as a Class 2 feedlot, it would still comply with the NSW S-Factor Guidelines.

Table 7 – S-Factor Calculation

Receptor	Direction	S1	S2	S3	S4	S5	Separation Distances	
							Required	Available
R3	WNW	57	0.3	1.2	1.0	1.0	653	1,270
R23	W	57	0.3	1.2	1.0	1.0	653	1,540
R25	N	57	0.3	1.2	1.0	1.0	653	1,150
R26	NE	57	0.3	1.2	1.0	1.0	653	1,350
R32	E	57	0.3	1.2	1.0	1.0	653	1,965
R38	SSE	57	0.3	1.2	1.0	1.0	653	1,905
R39	SSW	57	0.3	1.2	1.0	1.0	653	1,935
R44	SW	57	0.3	1.2	1.0	1.0	653	1,750

- S1 – The proposed feedlot will have a stocking density of 18 m²/SCU and average rainfall for the area is more than 750 mm/year.
- S2 – Single rural dwellings. The smallest property on Surrey Park Court exceeds 1 ha.
- S3 – The region is generally undulating. To ensure a conservative, simple assessment, it has been assumed that all receptors have a terrain of low relief with a slope of greater than 2 % and the receptor downslope. The terrain does not show confining sidewalls to the Beardy Waters valley.
- S4 – Although there are some trees in the landscape, the vegetation is identified as crops only.
- S5 – 9 am and 3 pm wind speed and direction plots for Glen Innes Airport, sourced from BOM, do not indicate winds with a high frequency, greater than 60 %, towards any sensitive receptor.

The risk of Q Fever to the surrounding dwellings has been considered. The NSW Health Q Fever Control Guideline (Q Fever Guideline) states that Q Fever can be transmitted several kilometres, usually in dust. As such, the key to minimising the risk of Q Fever transmission from the feedlot is dust control which is discussed in Section 4.

One of the studies identified in the Q fever Guideline, Tissot-Dupont *et al.*, (2004), refers to a Q Fever outbreak in the UK which resulted from transfer of contaminated hay along a major transport route. The other studies refer to outbreaks resulting from the grazing of cattle, sheep or goats and associated activities. These activities are all common in the Glen Innes region, with the New England Highway being a major agricultural transport route. The risk of

contracting Q Fever must always be considered when making the decision to live in a rural area.

3.4.2 SURFACE WATER

As the property is in the Glen Innes drinking water catchment, the effluent holding pond has been sized to contain effluent during a 90th percentile wet year (Appendix K). This complies with the requirements of the NSW Effluent Guidelines. It is extremely unlikely that the proposed feedlot will noticeably impact on raw water quality and, combined with the treatment of raw drinking water by GISC water treatment plants, will not impact treated drinking water quality.

The proposed feedlot has, as much as reasonably possible with consideration of other constraints, been separated from the nearest surface water features. The adjacent unmapped minor drainage line will be slightly diverted to ensure clean runoff flows around the proposed effluent holding pond. Surface water monitoring will occur once a year in rainfall events where both upstream and downstream surface waters are flowing simultaneously. As this is rainfall dependent it may not be possible during dry years. Surface water monitoring points have been identified on the Property Plan (Appendix A). This is proposed as the feedlot is in the Glen Innes drinking water catchment and this monitoring provides further confidence that any impact from the feedlot can be identified early and the impacts quantified.

3.4.3 GROUNDWATER

The nearest groundwater works summary (Appendix C) and Soil Investigation (Appendix B) identify a clay layer between the topsoil and porous basalt strata overlying the shallowest water-bearing zone. Laboratory analysis indicates that this clay material is suitable for formation of a clay liner which will minimise the potential of contaminants being leached into the groundwater. Pen cleaning and sustainable effluent and manure utilisation will minimise any further risk to groundwater.

3.4.4 TOPOGRAPHY

The natural slope of the feedlot site (3 %) (Section 2.4) is within the ideal range of 2 % to 4 % identified in the National Guidelines. Regardless, earthworks will ensure that the finished slopes of the feedlot pens are uniform and free-draining.

3.4.5 SOILS

The subsoils on the feedlot site are likely to contain a source of clay for the construction of the clay liner. If additional clay material is required, it will be sourced from within the property. The subsoils also contain the rock material which will be utilised for pen, drain and road surfaces.

The effluent irrigation and manure spreading areas are existing Class 3 or 4 cropping land. With appropriate land management (e.g. contour banks and spray irrigation management), these soils will be suitable for the proposed use. A nutrient mass balance has been undertaken to ensure there is adequate land available for effluent irrigation (Appendix K). Any excess manure can be removed for off-site utilisation.

3.4.6 ACCESS

The suitability of the access roads has been assessed in the Traffic Impact Assessment (Appendix J). No further upgrades are required or proposed. Internal access roads will be maintained to an all-weather standard.

3.4.7 EMERGENCIES AND NATURAL DISASTERS

An Emergency Management Plan (Emergency Plan) (Appendix L) has been prepared by Jardana. As the Emergency Plan appendices are available either within other appendices for the SEE Report, or publicly available online, they have not been included. However, they will be stored with the Emergency Plan into the future.

Given the significant elevation difference between the feedlot site and the banks of Beardy Waters, flood risk is extremely low. No further flood mitigation is required. Alternative escape routes are available to the property.

The property has limited vegetation and has been subject to extensive historical clearing. The feedlot site has a very low bushfire risk. As LPG storage is proposed at the feed preparation area, a Bushfire Protection Assessment has been completed for this area (Appendix M).

4 ENVIRONMENTAL MANAGEMENT PLAN

An environmental risk assessment allows for the environmental risks presented by the proposed development to be identified and minimised as much as reasonably possible. Environmental risk is determined by the potential consequences of the activity and the probability of those consequences occurring (Table 8). Appropriate management strategies can then be identified based on the risk. The below risk assessment (Table 9) also incorporates a Land Use Conflict Risk Assessment (LUCRA) in accordance with the LUCRA Guidelines.

The environmental risk assessment also incorporates a description of the environmental value, environmental objectives, potential impacts that could occur as a result of the feedlot development, design and management considerations to reduce environmental risk and specific tasks which will be undertaken as part of these management practices. As such, it provides a concise Environmental Management Plan (EMP) for the feedlot.

For the purposes of this environmental risk assessment, consequence is described as:

- Severe – Severe and/or permanent damage to the environment or impact on the community;
- Major – serious and/or long-term impact to the environment or community;
- Moderate – moderate and/or medium impact to the environment and community;
- Minor – minor and/or short-term impact to the environment and community; or
- Negligible – very minor impact to the environment and community.

Probability is described as:

- Almost certain – common or repeating occurrence;
- Likely – known to occur or has happened;
- Possible – could occur;
- Unlikely – could occur in some circumstances; or
- Rare – practically impossible.

Table 8 – Environmental Risk Assessment Matrix

Consequence	Probability				
	Almost Certain	Likely	Possible	Unlikely	Rare
Severe	25	24	22	19	15
Major	23	21	18	14	10
Moderate	20	17	13	9	6
Minor	16	12	8	5	3
Negligible	11	7	4	2	1

Table 9 – Environmental Risk Assessment and Management Plan

Environmental Value	Objective	Potential Impacts	Initial Risk	Design and Management	Actions	Residual Risk	Monitoring
<p>Surface Water</p> <p>There are various drainage features on the property. Any runoff from the feedlot site is captured by multiple dams prior to entering Beardy Waters. The site is located within the Glen Innes drinking water catchment.</p>	<ul style="list-style-type: none"> Comply with consent conditions. Prevent unreasonable impacts to surface water quality. Prevent impacts to the bed and banks of watercourses. Prevent increases in surface water velocity. 	<ul style="list-style-type: none"> Increase in contaminants in surface water resulting in algal blooms or damage to aquatic biodiversity. Erosion resulting in increased sediment loads. 	<p>Low-Medium (8)</p> <p>Consequences are minor and possible.</p>	<ul style="list-style-type: none"> The CDA has been designed to contain effluent in a 90th percentile wet year. This complies with the requirements of the NSW Effluent Guidelines. Due to the site topography, any overtopping events will be captured and diluted by the on-site dams. Construction will likely occur during dry periods. This, combined with the existing dams, reduces the risk of erosion and sediment transfer. 	<ul style="list-style-type: none"> Check effluent holding pond water level and drains weekly. Check sedimentation basin following rainfall and clean once sediment is dry. Inspect the structural integrity of the effluent holding pond and sedimentation basin when they are dry. Repair as required. Remove sediment from effluent holding pond when capacity is reduced by 20 % Notify GISC of an imminent overtopping event. Check soil has adequate capacity to absorb effluent prior to irrigation. Only irrigate at rates which prevent runoff. 	<p>Low (2)</p> <p>Consequences are negligible and unlikely.</p>	<p>Although the risk to surface water is low, upstream and downstream monitoring will occur during a flow event once a year, where rainfall allows. Still dam water is not an accurate indicator of water quality.</p>
<p>Groundwater</p> <p>The feedlot is located on land that is likely to be a recharge zone for basaltic aquifers. There is a 3 m clay layer below the topsoil.</p>	<ul style="list-style-type: none"> Comply with consent conditions. Prevent unreasonable impacts to groundwater quality. 	<ul style="list-style-type: none"> Increase in groundwater contaminants impacting on groundwater biodiversity or water supply to adjacent properties. 	<p>Low-Medium (8)</p> <p>Consequences are minor and possible.</p>	<ul style="list-style-type: none"> The CDA will be constructed with suitable materials and compaction to ensure a maximum permeability of 1×10^{-9} m/s (0.1 mm/day). The land available for effluent utilisation and manure spreading will ensure that minimal nutrient is leached into the groundwater. The clay layer will minimise any potential leaching of nutrients from the topsoil. 	<ul style="list-style-type: none"> Inspect the CDA surfaces following heavy rainfall or during extended dry periods. Evenly distribute manure and effluent across the available land. Record effluent irrigation and manure spreading events (date, area, application rate, etc.). 	<p>Low (2)</p> <p>Consequences are negligible and unlikely.</p>	<p>Due to the low residual risk to groundwater, ongoing monitoring is not proposed.</p>

STATEMENT OF ENVIRONMENTAL EFFECTS

Stonehenge Feedlot

Jardana Pty Ltd



Environmental Value	Objective	Potential Impacts	Initial Risk	Design and Management	Actions	Residual Risk	Monitoring
<p>Land</p> <p>The soil types at the feedlot site are suitable for construction and the surrounding on-site landscapes have high quality agricultural soils. There is native vegetation on the property but not immediately adjacent to the feedlot site or downslope of effluent irrigation areas.</p>	<ul style="list-style-type: none"> Minimise the impact of construction and development on the ongoing use of agricultural land Minimise the clearing or impact to remnant native vegetation Prevent unreasonable impacts to the physical and chemical structure of soils 	<ul style="list-style-type: none"> Fragmentation of agricultural land through development Loss of biodiversity associated with native vegetation Excessive soil nutrient levels Erosion of topsoil due to earthworks or breakdown of soil structure. 	<p>Low (2) Consequences are negligible and unlikely.</p>	<ul style="list-style-type: none"> Adequate effluent irrigation and manure spreading areas have been identified to prevent the accumulation of Phosphorous. The feedlot has been located on a site which requires no clearing of native vegetation and, with consideration of other constraints, the lowest quality agricultural land possible. Construction will be timed, where possible, to coincide with extended periods of dry weather. Adjacent areas disturbed during construction, including the outer banks of the effluent holding pond, will be revegetated with grass. 	<ul style="list-style-type: none"> Check exposed surfaces for erosion following heavy rainfall events Apply effluent and manure at suitable rates to ensure nutrient removal by the crop. Check soil moisture prior to irrigating effluent. Incorporate manure into the soil as soon as possible following spreading. 	<p>Low (1) Consequences are negligible and rare.</p>	<p>Due to the low residual risk to land (soils), no monitoring is proposed. However, ongoing agronomic testing is likely.</p>
<p>Community Amenity</p> <p>There are multiple sensitive receptors in the area with the nearest receptor 1,270 m from the feedlot complex.</p>	<p>Air</p> <ul style="list-style-type: none"> Comply with consent conditions. Prevent unreasonable odour and dust impacts on nearby sensitive receptors. 	<ul style="list-style-type: none"> Odour and dust have the potential to cause environmental nuisance. Excessive dust emissions have the potential to cause adverse health impacts (e.g. asthma). 	<p>Low-Medium (5) Consequences are minor and unlikely.</p>	<ul style="list-style-type: none"> In accordance with the National Guidelines, the proposed feedlot complies with the required separation distances for all nearby receptors. Ensure pen surfaces, drains, sedimentation basin are free draining. Maintain road surfaces to prevent excessive dust generation. Install a weather station to monitor weather conditions which will guide management practices. A native vegetation screen is proposed along the western edge of the development site. Plants will be planted prior to the commencement of construction and will be maintained. Due to the staging of the development, the visual screen will be established 	<ul style="list-style-type: none"> Clean pens at least every 13 weeks. Maintain pen and drain surfaces by repairing potholes and cleaning under fences. Maintain a small crushed rock stockpile on-site for pen, drain and road maintenance. Water internal roads during dry periods and grade surfaces as required. Clean sedimentation basin once sediment is dry. Maintain and, if required, replace plants within the vegetation screen. Maintain a complaints register. 	<p>Low (2) Consequences are negligible and unlikely.</p>	<p>Due to the low residual risk to community amenity, no monitoring is proposed.</p>

Environmental Value	Objective	Potential Impacts	Initial Risk	Design and Management	Actions	Residual Risk	Monitoring
				prior to the completion of the entire feedlot.			
Acoustic	<ul style="list-style-type: none"> Comply with consent conditions. Prevent unreasonable noise impacts on nearby sensitive receptors. 	<ul style="list-style-type: none"> Noise produced by operations and vehicle movements has the potential to cause environmental nuisance. The early starting hours and 24-hour 'operations' have the potential to impact on sleep. 	<p>Low (2) Consequences are negligible and unlikely.</p>	<ul style="list-style-type: none"> Noisy activities such as feeding and on-site vehicle movements generally occur between 6 am and 5 pm. The only operations that may occur outside the above hours are those required for animal welfare reasons (e.g. emergency maintenance). On-site vehicle speed limits of 30 km/hour will be signed and enforced and road surfaces maintained. 	<ul style="list-style-type: none"> Ongoing training and communication to ensure speed limits are observed. Identify any potholes during routine operations and repair as soon as possible. Maintain a small crushed rock stockpile on-site for road maintenance. Maintain a complaints register. 	<p>Low (1) Consequences are negligible and rare.</p>	Due to the low residual risk to the acoustic amenity, no monitoring is proposed.
Visual	<ul style="list-style-type: none"> Comply with consent conditions. Prevent unreasonable impacts to the visual landscape of the locality. 	<ul style="list-style-type: none"> The feedlot and associated buildings interrupt the rural landscape which is otherwise dominated by cropping and grazing. 	<p>Low-Medium (7) Consequences are negligible and likely.</p>	<ul style="list-style-type: none"> Due to the small size and rural nature of the feedlot, it has a limited impact on visual amenity in the region. The ancillary buildings are screened and cannot be seen from sensitive receptors or public roads. The proposed native vegetation screen will also assist in minimising the visibility of the feedlot. 	<ul style="list-style-type: none"> Maintain and replace any visible buildings to ensure they do not become an eyesore. Maintain and, if required, replace plants within the vegetation screen. 	<p>Low-Medium (7) Consequences are negligible and likely.</p>	N/A

5 PLANNING FRAMEWORK

5.1 GLEN INNES SEVERN COUNCIL

5.1.1 LAND USE STRATEGY

One of the guiding principles of the GISC land use strategy aims to '*ensure agriculture carries on into the future as a significant, environmental and economically sustainable industry with the capacity to capitalise on opportunities for intensification and diversification*'. The proposed development is perfectly aligned with this guiding principle as its primary goal is to allow for the existing farming operations to diversify and intensify to provide a long-term future for a small family business.

Not only does the proposed development align with the above guiding principle, it has also been designed and will be managed to protect the quality of local water supplies.

5.1.2 LOCAL ENVIRONMENTAL PLAN

Under the *Glen Innes Severn Local Environmental Plan 2012* (LEP), the property is in the RU1 – Primary Production Zone. Intensive livestock agriculture, such as the proposed development, is permitted, with consent, in the RU1 zone.

Clause 5.18 of the LEP incorporates the requirements of Part 3 of the State Environmental Planning Policy (SEPP) (Primary Production and Rural Development) 2019 (formerly SEPP 30). The objectives of this clause are:

- a) to ensure appropriate environmental assessment of development for the purpose of intensive livestock agriculture that is permitted with consent under this Plan, and
- b) to provide for certain capacity thresholds below which development consent is not required for that development subject to certain restrictions as to location.

Under this clause, in determining whether or not to grant consent for the proposed development, GISC must take the following into consideration:

- (a) the adequacy of the information provided in the statement of environmental effects or (if the development is designated development) the environmental impact statement accompanying the development application,

This report has been prepared by a suitably qualified person with extensive experience in the design and planning and environmental assessment of feedlots. This report addresses all relevant aspects of the feedlot to ensure it has been designed, and will be managed, in accordance with industry standards.

- (b) the potential for odours to adversely impact on the amenity of residences or other land uses within the vicinity of the site,

Nearby sensitive receptors and surrounding land use has been identified in Section 2.3. The feedlot has been adequately separated from all nearby sensitive receptors (Section 3.4.1).

- (c) the potential for the pollution of surface water and groundwater,

The environmental values of surface water and groundwater are identified in Sections 2.6 and 2.7, respectively. The feedlot will be located in a CDA which has been designed in accordance with the National Guidelines (Section 3.3). The suitability of the site with respect to these environmental values is addressed in Section 3.4.2

- (d) the potential for the degradation of soils,

The on-site soils and land and soil capability are discussed in Section 2.5. Construction of the feedlot and the long-term utilisation of effluent have the potential to impact soils. Erosion and sediment control during construction is discussed in Section 3.1.8.1 and the long-term sustainability of effluent and manure management is discussed in Sections 3.3.6, 3.3.7, and 3.4.5.

- (e) the measures proposed to mitigate any potential adverse impacts,

The feedlot has been designed and will be managed in accordance with the National Guidelines and Environmental Code of Practice. Section 3 provides information on the design of the proposed feedlot and Section 4 details the proposed management practices. The design and management of the feedlot will ensure any potential adverse impacts are prevented or minimised as much as reasonably possible.

- (f) the suitability of the site in the circumstances,

The feedlot design has been completed with due consideration of the site and any potential limitations. Site suitability is further discussed in Section 3.4.

- (g) whether the applicant has indicated an intention to comply with relevant industry codes of practice for the health and welfare of animals.

The feedlot will maintain animal welfare standards in accordance with the *Australian Animal Welfare Standards and Guidelines for Cattle*. Feedlot design has appropriately considered animal welfare.

5.1.3 DEVELOPMENT CONTROL PLAN

The *Glen Innes Severn Council Development Control Plan 2014* (DCP) identifies various controls and provisions to guide development in the GISC local government area. The chapters of the DCP relevant to the proposed development have been addressed below.

5.1.3.1 Chapter 2 – Notification Procedures

The proposed development will require both neighbour notification and public advertising for a minimum of 14 days.

5.1.3.2 Chapter 4 – Rural Development

Chapter 4 controls apply to all development, such as the proposed feedlot, in the RU1 – Primary Production zone. The aims and objectives of this chapter are:

- To enhance the character of the rural areas.

The proposed development is a rural activity in a rural area and provides an economic benefit to the region through direct and indirect contributions. The additional cattle and feed which cannot be supplied from on-site production will be sourced locally, benefiting a range of local farming families. It will also provide an alternate income for the property during drought periods and further drought proof a fifth-generation farming family. In recent dry years, demand from feedlot space across the country has remained high as cattle cannot be sustained on pastures. Construction materials and labour, where possible, will also be sourced locally.

- To encourage the use of existing or potentially productive land for agricultural purposes.

The feedlot has been located to avoid the highly productive land on other parts of the property. It is located on an area mapped as Class 6 land which is the lowest quality land mapped on the property. The use of manure and effluent from the feedlot will also aid in increasing the organic matter in agricultural soils.

- To reduce potential for rural land use conflict.

The proposed development has been designed and sited in accordance with the National Guidelines and NSW S Factor guideline. There is extensive separation between the proposed development and the nearest sensitive receptors.

- To protect old-growth, significant hollow-bearing trees and conservation significant vegetation through recognition of their ecological value and scarcity in the landscape.

Clearing of native trees will not be required for the proposed development.

- To improve the ecological function of riparian areas within the landscape.

The feedlot and effluent irrigation areas have been located to avoid the riparian land on the property. The CDA will ensure runoff is appropriately captured and contained to prevent uncontrolled releases into riparian areas.

- To improve the stability of the bed and banks of waterways through the management of riparian vegetation.

As per above, the proposed development will not alter the bed or banks of waterways or riparian vegetation.

Specific rural development controls within the DCP have been addressed in Table 10.

Table 10 – GISC DCP Rural Development Controls

Control	Compliance Assessment
General Controls	
Rural dwellings and dual occupancies are subject to the provisions of Clause 4.2A of the GISC LEP 2013.	N/A – additional rural dwellings are not proposed.
Council may require the consolidation of undersized rural lots (vacant lots with an area of less than the minimum rural lot size) within the same rural property holding as a condition of consent for new rural dwellings.	The existing lots are adequately sized for rural production. Regardless, prior to commencement of the feedlot, all lots included in the development application will be amalgamated into a single lot.
Buildings shall be sited so that they are not located or project above ridgelines or knolls and are sensitively placed within the rural landscape.	The feedlot is on the side of a hill and structures will not project above a ridgeline or knoll. Additional feed storage buildings (including silos) are proposed adjacent to similar existing buildings. This area is screened by existing trees.
Rural buildings, including garages and sheds should be clustered to form a group and where possible, buildings shall be broken into smaller elements rather than presenting a large building mass.	As above.
All buildings should be setback at least 15 metres from the front property boundary (with frontage to a public road).	All buildings and structures will be set back several hundred metres from the property boundary.
Materials and/or finishes should not give rise to visual intrusion by virtue of texture, colour or arrangement. The use of recessive earthy tones is required. The use of reflective materials is discouraged.	The buildings and structures proposed (silos, feed sheds, fences and earthworks) are all rural in nature.
Development involving the on-site management of wastewater must comply with Council's Onsite Sewage Management Strategy.	Industry standard effluent controls will be implemented in the feedlot (Section 3.3). Existing dwellings will be utilised for amenities. No further toilets or amenities are proposed.
Development within bushfire prone land must meet the relevant requirements of the Rural Fire Service and <i>Planning for Bushfire Protection 2019</i> .	N/A – the proposed development is not located on bushfire prone land. Regardless, a Bushfire Protection Assessment has been completed (Appendix M).
The carrying out of development ('works' including excavation or deposition of material) on waterfront land requires a Controlled Activity Approval (CAA) under the <i>Water Management Act 2000</i> . Council will refer DAs involving works within waterfront land to the NSW Office of Water as integrated development.	N/A – no works will be undertaken on waterfront land.

STATEMENT OF ENVIRONMENTAL EFFECTS

Stonehenge Feedlot

Jardana Pty Ltd



Control	Compliance Assessment
Vehicular Access Requirements	
Access to a development shall be located having regard to its potential impact on the landscape and native vegetation and shall be unobtrusive and sympathetic to the existing landform and neighbouring development.	The proposed feedlot access is not located on or adjacent to native vegetation. Pedlow's Road does not provide access to any other properties and the proposed access will be suitably constructed for B-Doubles. The existing access to the property will be utilised for feed deliveries.
All development is required to have coincidental legal and physical access from a public road to the development site. In this regard, Council may require evidence from a registered surveyor that this is the case.	The proposed access is from Pedlow's Road which is a public road.
Where a part of any access is via an unformed Crown road, the road may first require dedication as a Council public road, and then construction to an appropriate standard once Council approval has been gained for the work. For a single residential dwelling, the minimum standard of construction where the owner will be responsible for ongoing track maintenance is in accordance with the former Department of Land and Water Conservation publication "Guidelines for the Planning, Construction and Maintenance of Tracks".	N/A – an unformed Crown (paper) road is not utilised for access.
Road and drainage designs may need to be submitted to Council at the applicant's expense prior to approval of any roadworks within a Council public road reserve.	If any works are required for the crossover from Pedlow's Road into the property, all necessary approvals will be gained prior to construction.
The developer will be responsible for construction or upgrading of any vehicle access in accordance with Council standards.	Any upgrade works required will be completed by Jardana.
Environmental Considerations	
Development shall not be carried out on slopes greater than 20%. If development on slopes greater than 20% is unavoidable, Council may require a geotechnical assessment.	The subject site has an average slope of 3 % which is ideal for feedlot construction.
Clearing of native vegetation – applications are to identify the area and number of trees to be cleared as part of the application. Clearing which does not form part of a Development Application to Council must be approved by the relevant Local Land Services (LLS) (refer to Note below).	No clearing of native vegetation is required or proposed.
Where development is likely to have a significant impact on threatened species, populations or ecological communities, or their habitats within the meaning of the <i>Threatened Species Conservation Act 1995</i> , <i>Environment Protection and Biodiversity Conservation Act (EPBC) Act</i>	The clearing of native trees will not be required for the proposed development. There is no potential impact on threatened species, ecological communities or their habitats (Section 2.8)

STATEMENT OF ENVIRONMENTAL EFFECTS

Stonehenge Feedlot

Jardana Pty Ltd



Control	Compliance Assessment
1999 and <i>Fisheries Management Act 1994</i> ., Council will require an ecological assessment, preliminary Vegetation Management Plan, and compensatory planting.	
Riparian lands within a subdivision are to be stabilised and revegetated according to stream order and buffer category. Water courses classified as stream order 3 or greater (Strahler method) require a riparian buffer of at least 40 m.	Development is not proposed on riparian lands.
Roads are to be located outside riparian buffer areas where possible. Where roads traverse the riparian buffer area, the road design is to minimise the area of disturbance and demonstrate minimal impact on the riparian function and integrity.	No new roads are proposed.
Driveway/roadway crossings/other infrastructure located over waterways are to have regard to the requirements for fish passage in accordance with relevant NSW State Government requirements under the <i>Fisheries Management Act 1994</i> .	The internal driveway does not intersect with any waterways or drainage lines.
Flooding	
In low-lying areas, a flood study may be required to determine appropriate floor levels for habitable structures. Waterway crossings on any access roadways should be designed to permit two-wheel drive access from a public road to the residence during a critical one (1) in 100-year storm event.	The proposed feedlot is not located in a low-lying area. The feedlot elevation is approximately 20 m higher than Beardy Waters.
Land Use Buffers	
Buffers from development to rural land uses are to be established in accordance with the NSW DPI Land Use Conflict Risk Assessment Guide.	The proposed feedlot has been sited in accordance with the National Guidelines (Section 3.4.1).
Where a proposed development for a dwelling or tourist accommodation will adjoin an agricultural enterprise on an adjoining property, a minimum 100 m separation shall be provided. Where the 100 m buffer cannot be achieved, Council will consider the use of vegetative buffers on the proposed development site.	The proposed development does not include a dwelling or tourist accommodation.
Any new residence should be located a minimum distance of 2 km from any active or proposed wind turbine, unless suitable measures are taken in the design and construction of the dwelling to ameliorate any noise or other impacts.	No new residences are proposed.
Glen Innes Aerodrome	
Where a development will be located in the vicinity of the Glen Innes Aerodrome, the following additional controls will apply:	The development is not located in the vicinity of the Glen Innes Aerodrome.

STATEMENT OF ENVIRONMENTAL EFFECTS

Stonehenge Feedlot

Jardana Pty Ltd



Control	Compliance Assessment
<ul style="list-style-type: none"> All structures, and the mature height of any vegetation, is to remain below the obstacle limitation surface for Glen Innes Aerodrome, Further details of these levels are available from Council's Department of Infrastructure Services The dwelling and any landscaping, including dams, shall be designed and located so as to discourage feeding and nesting sites for birds in the vicinity of flight paths All building materials and outdoor lighting shall be designed or shielded so as to minimise any upward glare in the vicinity of flight paths Any residence is to be located and designed in accordance with the provisions of AS2021 'Acoustics – Aircraft Noise Intrusion – Building Siting and Construction', outside the 20 ANEF noise contour for Glen Innes Aerodrome. 	
Services	
Any structures associated with the provision of electricity and telecommunications to the development shall be sited to have minimal environmental impact including vegetation removal and visual impact.	No further electricity or telecommunications infrastructure is proposed. Existing electricity supply at the dwelling and feed storage area will be adequate for the proposed expansion. Portable generators will be utilised, where required, for construction or maintenance work at the feedlot.
Applications are required to demonstrate the method of power supply.	
Council supports the use of solar energy supplies.	Solar panels are installed on existing buildings in the feed storage area.
Where generators are proposed, controls shall be placed on the hours of operation and levels of noise emission having regard to the proximity of neighbouring development and the environment.	No additional, permanent generators are proposed. Portable generators will only be utilised during daylight hours unless in an animal welfare emergency.
Rural buildings without a reticulated water supply shall have water storage facilities containing a minimum of 22,000 litres of potable water for domestic purposes.	The proposed rural buildings do not require any further water supply.
Farm Dams	
<p>The NSW Office of Water regulates and licenses farm dams. Dams that do not need a licence or development consent are:</p> <ul style="list-style-type: none"> Dams that capture up to 10 per cent of run-off. Dams up to one megalitre on small properties. 	The total volume of all the existing dams on the property does not exceed the maximum harvestable right of 10 % of runoff.

5.1.3.3 Chapter 7 – Access and Parking

Chapter 7 applies to new development in all zones. The aims and objectives of this chapter are to ensure that new development:

- maintains or improves traffic safety and management;

A Traffic Impact Assessment has been completed (Appendix J). Pedlow’s Road does not provide access to any other properties. As such, an assessment of this road has not been completed. The required crossover will be suitably designed for B-Double access.

- provides adequate provision for access and parking for people with disabilities;

Given the nature of the feedlot development and available open space, no specified access or parking for people with disabilities has been provided.

- minimises the visual impact of on-site parking. and

On-site parking has been provided in the form of open hardstand areas which is suitable for the rural nature of the feedlot.

- provides for the ongoing maintenance of on-site car parking and manoeuvring areas.

On-site parking has been provided in the form of open hardstand areas which is suitable for the rural nature of the feedlot. As the site is accessed by B-Doubles, the access is suitable for any other service vehicles including fire-fighting vehicles.

Specific parking controls within the DCP have been addressed in Table 11.

Table 11 – GISDC DCP Parking Controls

Control	Compliance Assessment
Parking Controls	
Car-parking spaces are to be provided on the same lot as the proposed development. Multi-lot land holdings may require consolidation to comply with this control. (Reason: To ensure car parking remains annexed to the approved development.)	There is adequate open space available for parking. The feedlot is not open to the public.
Additional parking spaces required for any new development or redevelopment shall comply with the controls of this chapter and Table 7.1: Off-street Parking Rates.	No additional parking spaces are required for the feedlot.
Accessible car parking spaces are to be provided in accordance with the Disability (Access to Premises - Buildings) Standards 2010.	Given the nature of the feedlot development and available open space, no specified access or parking for people with disabilities has been provided.
Accessible car parking spaces are to be located as close as possible to the main pedestrian entrance and should have regard to the use and function of the building.	
Council will apply the controls of this Chapter if it considers a proposed Change of Use requiring consent will produce a substantially different parking requirement than those attributable to the previous use of premises.	The proposed change of use will not produce a substantially different parking requirement.

Control	Compliance Assessment
Development proposals that provide less parking than required by this Chapter shall be supported by a parking study.	Parking requirements for feedlots are not specified. There is adequate open space for vehicle parking.
On-site parking design must meet the relevant Australian Standards (AS 2890.1 and 2890.2 2004).	On-site parking is suitable for the rural nature of the use.
All required car parking areas, driveways, turning areas and loading areas are paved in either a bitumen seal coat, asphaltic or bituminous concrete, cement concrete, concrete paving blocks, or brick paving blocks. The standard of paving required will be dependent upon the type of development proposed, with regard to traffic loadings including turning movements of heavy-vehicles.	The proposed access and cross-over will provide all-weather gravel access which is suitable given the rural nature of the feedlot.
In villages and rural areas all-weather paving of driveways, turning areas, loading areas and car parking areas is required. Surface materials to be at the discretion of Council's Director of Infrastructure Services.	
All parking spaces shall be suitably line-marked and sign-posted and be graded and drained to Council's stormwater system.	Given the rural nature of the development, park delineation is not required.
Free and uninterrupted access to car parking areas shall be maintained at all times.	As the feedlot is not open to the public, access to private property will be controlled.
Stacked car parking is only permissible in conjunction with single dwelling houses and dual occupancies. Exceptions to this control are at the discretion of Council.	N/A
Car parking areas are to be incorporated into the building or provided at, or behind, the front setback of the building.	Car parking is available next to the location in which vehicles are servicing.

5.1.3.4 Chapter 12 – Statement of Environmental Effects Requirements

This document provides the necessary information to comply with Chapter 12.

5.2 STATE ENVIRONMENTAL PLANNING POLICIES

5.2.1 PRIMARY PRODUCTION AND RURAL DEVELOPMENT

Schedule 4, Part 3, Clause 4 of the Primary Production and Rural Development SEPP identifies the aspects of a proposed development the consent authority must consider. The requirements of this Clause have been incorporated into the LEP and are addressed in Section 5.1.2.

5.2.2 HAZARDOUS AND OFFENSIVE DEVELOPMENT

Approximately 18,000 L of gas storage will be required for the grain roaster. There are existing diesel storage tanks utilised as part of routine farm operations. No additional fuel storage is proposed. The proposed use is not defined as an industry use and, according to Section 6.1, Question 6.5 of the *Hazardous and Offensive Development Application Guidelines*, the requirements of SEPP 33 are unlikely to apply to a cattle feedlot. Fuel is a C1 combustible liquid and, as it is not stored with other combustible liquids not considered to be potentially

hazardous. Given the rural and remote nature of the LPG storage, a detailed Preliminary Hazard Analysis should not be required.

The feedlot is considered a potentially offensive industry and this report addresses potential offence caused by the feedlot and design and management practices implemented to reduce that offence.

5.2.3 KOALA HABITAT PROTECTION

The proposed feedlot will not require the clearing of native vegetation. The patch of trees south of the proposed feedlot is mapped as containing vegetation subject to considerations under the Koala Habitat Protection SEPP. However, the proposed feedlot will not impact on these trees.

5.2.4 REMEDIATION OF LAND

As the site is greenfield and located on agricultural land which has been cultivated for many years, there is a low risk of substantial contamination. However, the paddocks where the feedlot is proposed have been subject to historical chemical applications. The historic use of agricultural chemicals will not impact on the use of the site for the proposed development.

The proposed development will require the removal and stockpiling of topsoil prior to it being spread for the establishment of grass cover on disturbed areas not subject to development. Any remaining topsoil will be retained in stockpiles and revegetated to provide further visual screening.

5.2.5 ADVERTISING AND SIGNAGE

Signage identifying the property, company and operations may be erected at the property entrance. However, this signage is exempt development under the Exempt and Complying Development Codes SEPP. Therefore, the Advertising and Signage SEPP does not apply.

5.2.6 INFRASTRUCTURE

The proposed development is defined as intensive livestock agriculture which is not listed in Schedule 3 of the Infrastructure SEPP. Additionally, it will not generate more than 200 motor vehicles per hour. The property is also not adjacent to a classified road or rail corridor. As such, the Infrastructure SEPP does not apply to the proposed development.

6 CONCLUSION

The proposed development is ideally located and designed in accordance with the National Guidelines, the GISC LEP and DCP and relevant SEPPs. It is a rural development in a rural area and the surrounding environment, both built and natural, will be protected through the design and proposed management. As such, the proposed development should be approved.

7 REFERENCES

Davis, R. J., Wiedemann, S. G. and Watts, P. J. (2008) *Quantifying the water and energy usage of individual activities within Australian feedlots - Part B energy usage at Australian Feedlots*. Sydney, NSW: Meat & Livestock Australia Limited.

Tissot-Dupont, H. *et al.* (2004) 'Wind in November, Q fever in December', *Emerging infectious diseases*. Centers for Disease Control and Prevention, 10(7), pp. 1264–1269. doi: 10.3201/eid1007.030724.

APPENDIX A – DESIGN PLANS

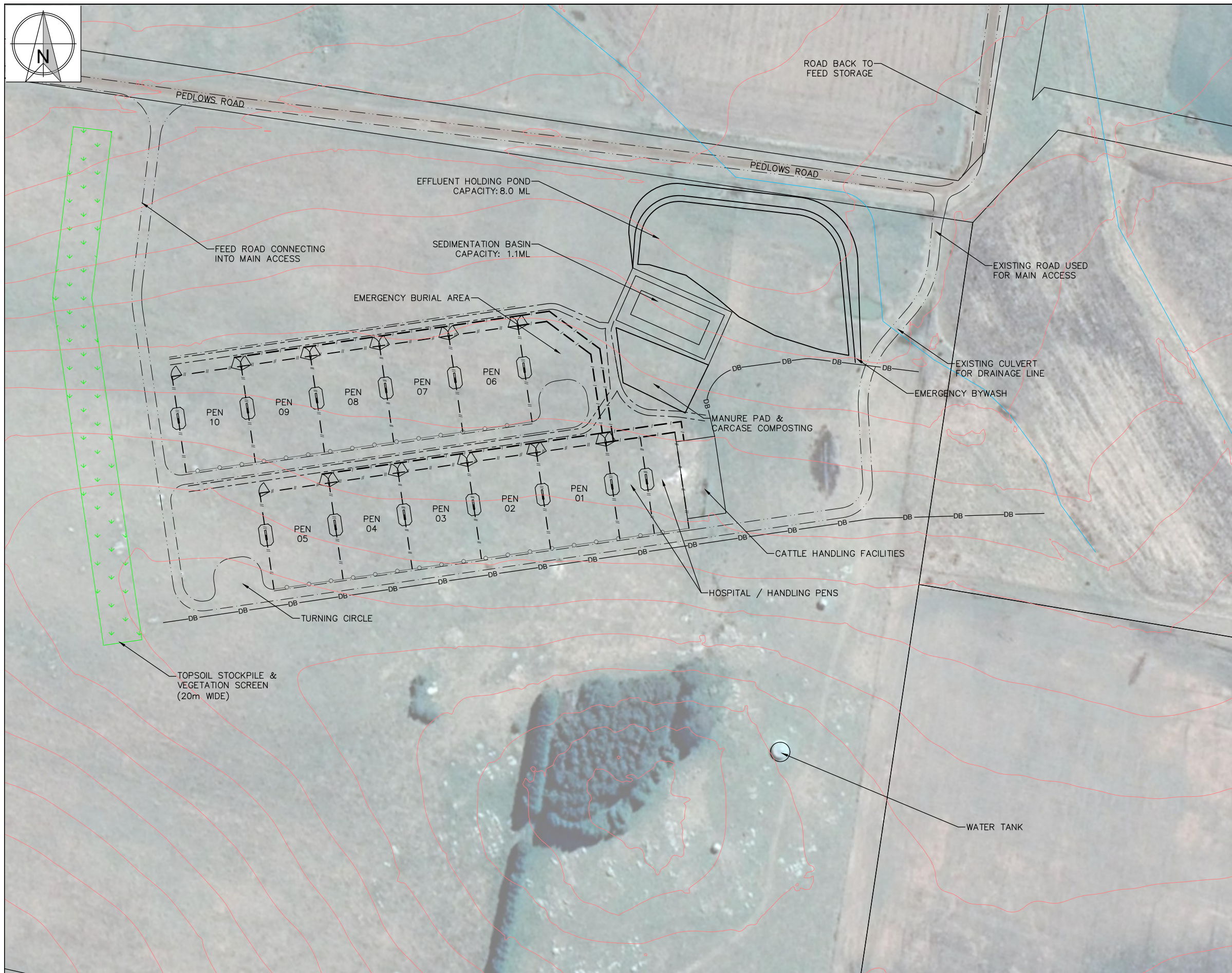

LEGEND – PROPOSED

- CONTOUR – EXISTING (1.0m)
- PEN FENCE
- CATTLE LANE
- FEED BUNK
- COMMODITY ROAD
- FEED ROAD
- EFFLUENT DRAIN
- CLEAN WATER DIVERSION BANK
- VEGETATION SCREEN (20m WIDE)
- DRAINAGE LINE

NOTES

1. AERIAL IMAGE SOURCED THROUGH GOOGLE EARTH PRO. IMAGE DATE 11/05/2020.
2. FEATURES MAY HAVE BEEN DIGITISED FROM PLANS OR AERIAL PHOTOGRAPHS AND ACCURACY IS LIMITED.
3. THE REQUIRED SEDIMENTATION BASIN CAPACITY HAS BEEN CALCULATED USING THE EQUATIONS OUTLINED IN THE NSW FEEDLOT MANUAL (1997) & THE NATIONAL GUIDELINES FOR BEEF CATTLE FEEDLOTS IN AUSTRALIA 3RD ED (2012). THE PROPOSED VOLUME INCLUDES A 20% STORAGE BUFFER TO ACCOUNT FOR ACCUMULATED SOLIDS.
4. THE REQUIRED EFFLUENT HOLDING POND CAPACITY HAS BEEN CALCULATED USING A DAILY TIME-STOP HYDROLOGICAL MODEL AS REQUIRED IN THE NSW FEEDLOT MANUAL (1997). THE CATCHMENT DATA USED IN THE MODEL IS CONSISTENT WITH THE DETAILS PROVIDED IN A005 – CATCHMENT PLAN (PED-001). THE POND HAS BEEN SIZED FOR A 90TH PERCENTILE YEAR. THEREFORE, A MAXIMUM OF 5 OVERTOPPING EVENTS ACROSS THE 50 YEAR HYDROLOGICAL BALANCE.

DESIGN: PRODUCTION PENS

1. STOCKING DENSITY = 18.0 m²/SCU
2. BUNK SPACE = 360 mm/SCU
3. PENS 36.0m x 50.0m = 1,800 m²/PEN
4. INDIVIDUAL PEN CAPACITY = 100 SCU
5. NEW PRODUCTION PENS = 10
6. CAPACITY = 1,000 SCU

DESIGN: GENERAL FACILITY

1. FEED ROAD WIDTH = 5.0 m
2. BUNK WIDTH = 1.0 m
3. CATTLE LANE = 5.0 m
4. DRAIN WIDTH = 3.0 m

CLIENT
JARDANA PTY LTD

PROJECT
JARDANA FEEDLOT DEVELOPMENT

LOCATION
34 PEDLOWS ROAD, GLEN INNES NSW 2370

SHEET TITLE
CONCEPT PLAN

AGRICULTURAL DEVELOPMENT SERVICES AUSTRALIA

PO BOX 292
TOOWOOMBA QLD 4350
PH: +61 418 446 245
E: contact@agdsa.com.au

SCALE

SCALE 1:1,000 (A1)

SCALE 1:2,000 (A3)

JARDANA PTY LTD

DESIGNED
TJS

CHECKED
MRN

PROJECT MANAGER
MRN

PRELIMINARY – FOR APPROVAL ONLY			
DATE	REV	DESCRIPTION	TJS
06/10/2020	A	ORIGINAL ISSUE	APP
REVISIONS			

JOB CODE
PED-001

SHEET NUMBER
A001

CURRENT REVISION
A

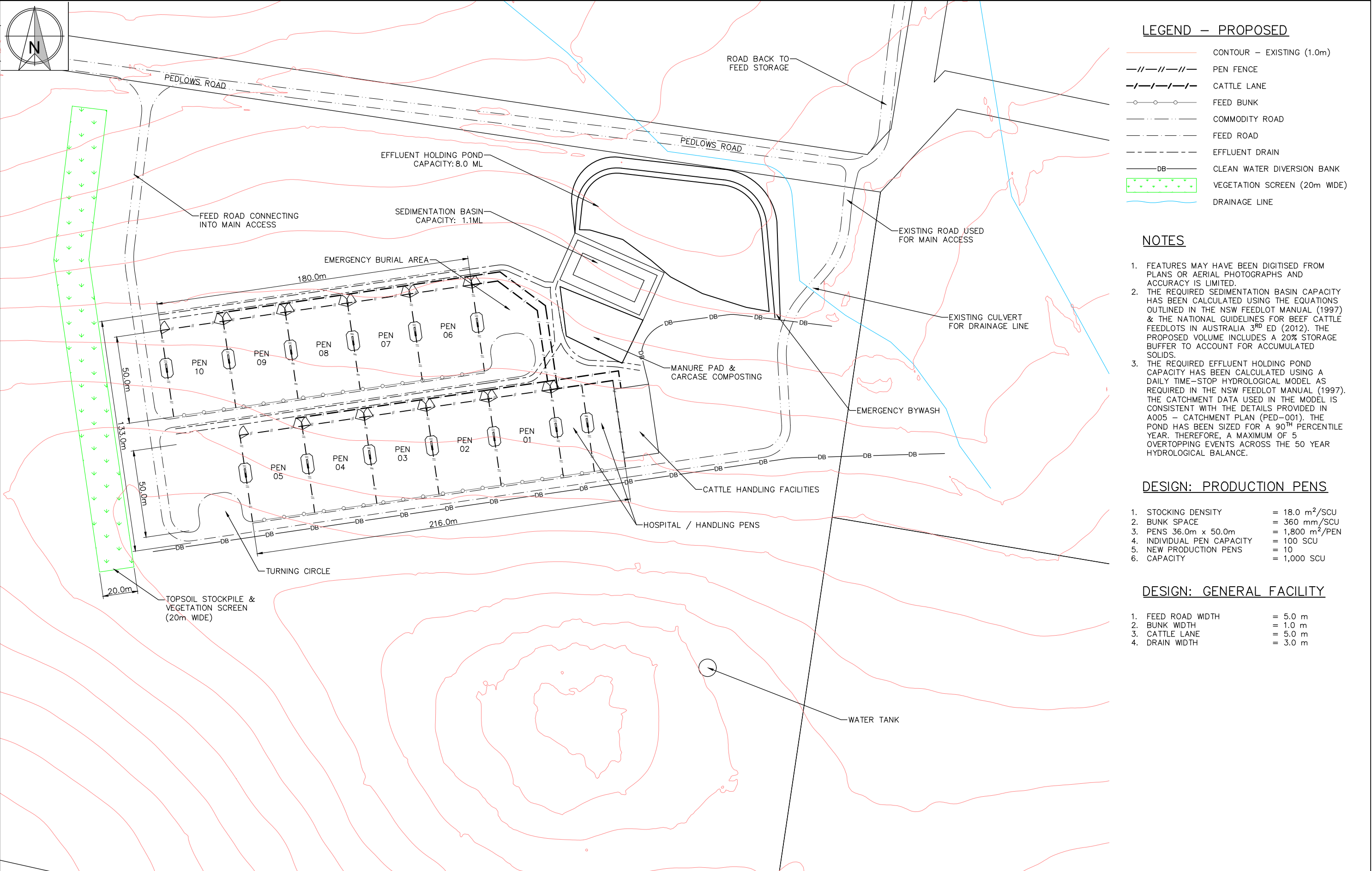

CLIENT
JARDANA PTY LTD

PROJECT
JARDANA FEEDLOT DEVELOPMENT

LOCATION
34 PEDLOWS ROAD, GLEN INNES NSW 2370

SHEET TITLE
DESIGN LAYOUT

AgDSA
 AGRICULTURAL DEVELOPMENT SERVICES AUSTRALIA

PO BOX 292
 TOOWOOMBA QLD 4350
 PH: +61 418 446 245
 E: contact@agdsa.com.au

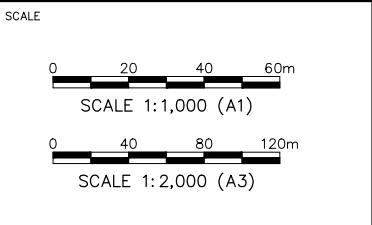

JARDANA PTY LTD

DESIGNED
TJS

CHECKED
MRN

PROJECT MANAGER
MRN

PRELIMINARY – FOR APPROVAL ONLY

DATE	REV	DESCRIPTION	TJS	APP
06/10/2020	A	ORIGINAL ISSUE		

REVISIONS

JOB CODE
PED-001

SHEET NUMBER
A002

CURRENT REVISION
A

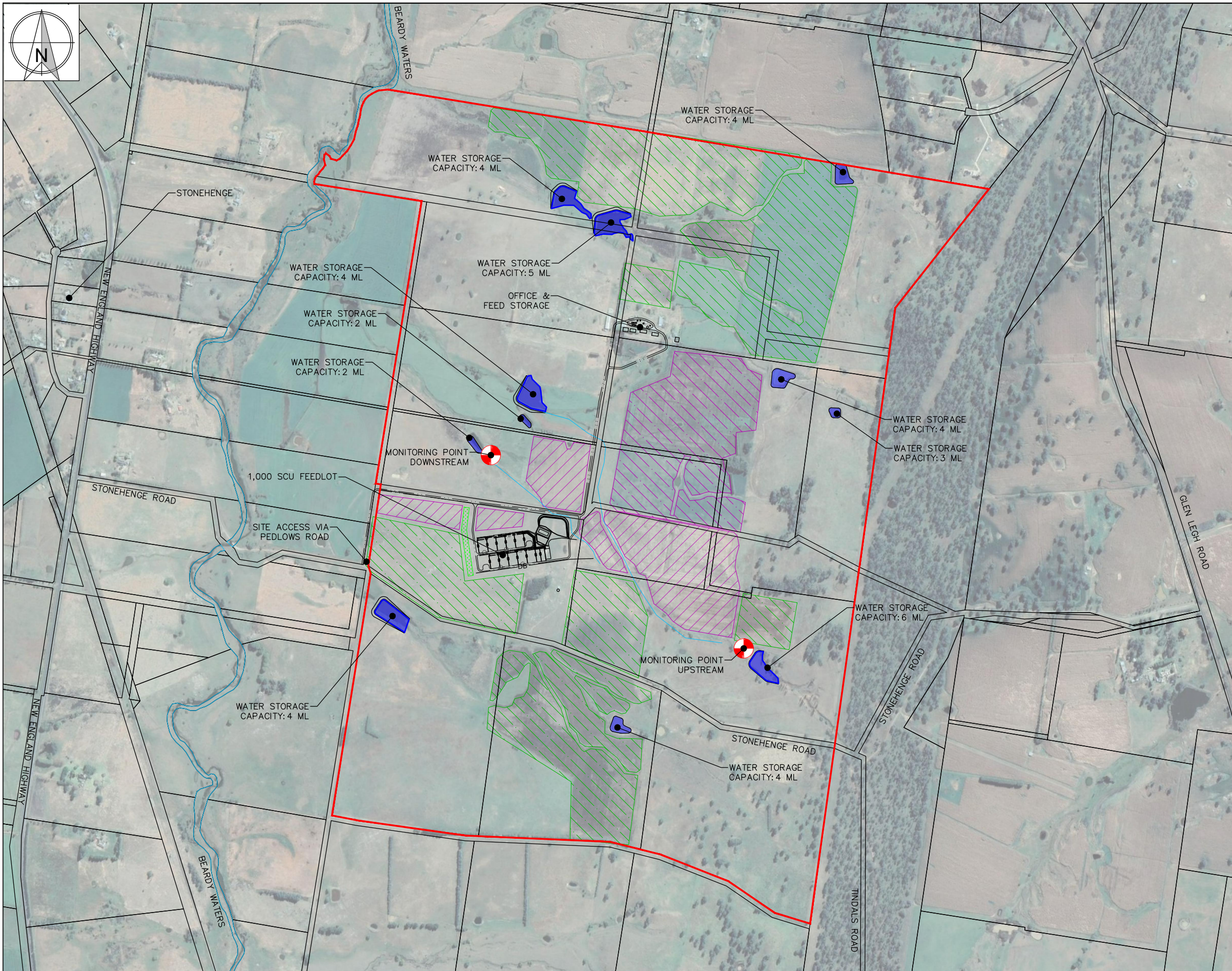
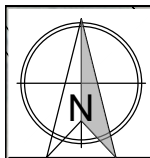

LEGEND – PROPOSED

- PROPERTY BOUNDARY
- LOT BOUNDARY
- FEED ROAD
- EXISTING WATER STORAGE (COMBINED 42ML)
- EUA – EFFLUENT UTILISATION AREA (54.8 ha)
- MUA – MANURE UTILISATION AREA (115.1 ha)
- VEGETATION SCREEN (20m WIDE)
- SURFACE WATER MONITORING POINT

NOTES

1. AERIAL IMAGE SOURCED THROUGH GOOGLE EARTH PRO. IMAGE DATE 11/05/2020.
2. CADASTRAL DATA SOURCED THROUGH NSW SIX MAPS. DATA SOURCED 3/09/2020.
3. FEATURES MAY HAVE BEEN DIGITISED FROM PLANS OR AERIAL PHOTOGRAPHS AND ACCURACY IS LIMITED.

CLIENT
JARDANA PTY LTD

PROJECT
JARDANA FEEDLOT DEVELOPMENT

LOCATION
34 PEDLOWS ROAD, GLEN INNES NSW 2370

SHEET TITLE
PROPERTY PLAN – AERIAL IMAGE

PO BOX 292
TOOWOOMBA QLD 4350
PH: +61 418 446 245
E: contact@agdsa.com.au

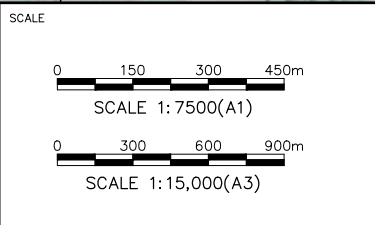

JARDANA PTY LTD

DESIGNED
TJS

CHECKED
MRN

PROJECT MANAGER
MRN

PRELIMINARY – FOR APPROVAL ONLY		
DATE	REV	DESCRIPTION
REVISIONS		

JOB CODE
PED-001

SHEET NUMBER
A003

CURRENT REVISION
A

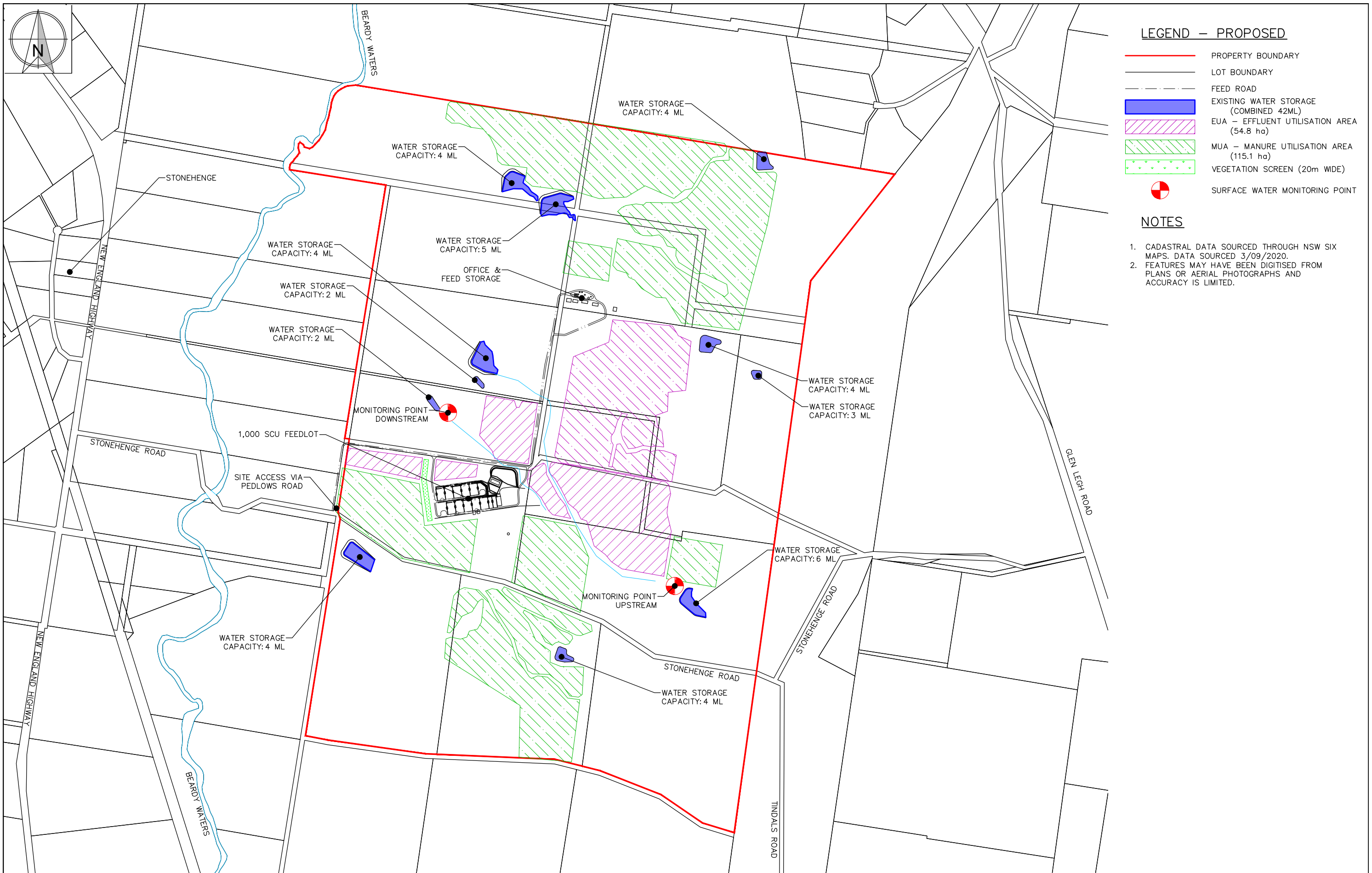

LEGEND – PROPOSED

- PROPERTY BOUNDARY
- LOT BOUNDARY
- FEED ROAD
- EXISTING WATER STORAGE (COMBINED 42ML)
- EUA – EFFLUENT UTILISATION AREA (54.8 ha)
- MUA – MANURE UTILISATION AREA (115.1 ha)
- VEGETATION SCREEN (20m WIDE)
- + SURFACE WATER MONITORING POINT

NOTES

1. CADASTRAL DATA SOURCED THROUGH NSW SIX MAPS. DATA SOURCED 3/09/2020.
2. FEATURES MAY HAVE BEEN DIGITISED FROM PLANS OR AERIAL PHOTOGRAPHS AND ACCURACY IS LIMITED.

CLIENT
JARDANA PTY LTD

PROJECT
JARDANA FEEDLOT DEVELOPMENT

LOCATION
34 PEDLOWS ROAD, GLEN INNES NSW 2370

SHEET TITLE
PROPERTY PLAN



AGRICULTURAL DEVELOPMENT SERVICES AUSTRALIA

PO BOX 292
 TOOWOOMBA QLD 4350
 PH: +61 418 446 245
 E: contact@agdsa.com.au

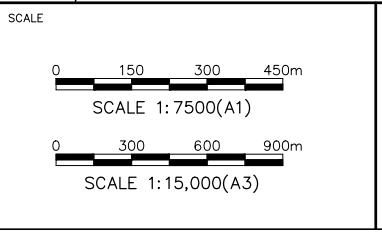

JARDANA PTY LTD

DESIGNED
 TJS

CHECKED
 MRN

PROJECT MANAGER
 MRN

PRELIMINARY – FOR APPROVAL ONLY

DATE	REV	DESCRIPTION	TJS	APP
06/10/2020	A	ORIGINAL ISSUE		

REVISIONS

JOB CODE
PED-001

SHEET NUMBER
A004

CURRENT REVISION
A



LEGEND – PROPOSED

- PEN FENCE
- CATTLE LANE
- FEED BUNK
- EFFLUENT DRAIN
- FEED ROAD
- COMMODITY ROAD
- CLEAN WATER DIVERSION BANK
- CATCHMENT BOUNDARY
- MAXIMUM DRAIN LENGTH (280m)
- VEGETATION SCREEN (20m WIDE)
- DRAINAGE LINE

NOTES

1. IN THE ABSENCE OF SITE SPECIFIC SURVEY DATA, CATCHMENT BOUNDARIES HAVE BEEN DETERMINED USING 2.0m LIDAR CONTOUR DATA SOURCED FROM NSW SIXMAPS.
2. FEATURES MAY HAVE BEEN DIGITISED FROM PLANS OR AERIAL PHOTOGRAPHS AND ACCURACY IS LIMITED.
3. THE REQUIRED SEDIMENTATION BASIN CAPACITY HAS BEEN CALCULATED USING THE EQUATIONS OUTLINED IN THE NSW FEEDLOT MANUAL (1997) & THE NATIONAL GUIDELINES FOR BEEF CATTLE FEEDLOTS IN AUSTRALIA 3RD ED (2012). THE PROPOSED VOLUME INCLUDES A 20% STORAGE BUFFER TO ACCOUNT FOR ACCUMULATED SOLIDS.
4. THE REQUIRED EFFLUENT HOLDING POND CAPACITY HAS BEEN CALCULATED USING A DAILY TIME-STOP HYDROLOGICAL MODEL AS REQUIRED IN THE NSW FEEDLOT MANUAL (1997). THE CATCHMENT DATA USED IN THE MODEL IS CONSISTENT WITH THE DETAILS PROVIDED IN A005 – CATCHMENT PLAN (PED-001). THE POND HAS BEEN SIZED FOR A 90TH PERCENTILE YEAR. THEREFORE, A MAXIMUM OF 5 OVERTOPPING EVENTS ACROSS THE 50 YEAR HYDROLOGICAL BALANCE.

CONTROLLED DRAINAGE AREA

	PEN AREA	= 1.800 ha
	SOFT AREA	= 0.391 ha
	HARD AREA:	= 1.498 ha
	MANURE PAD AREA:	= 0.113 ha
	BASIN AREA	= 0.125 ha
	POND AREA	= 0.535 ha
	TOTAL CATCHMENT	= 4.462 ha

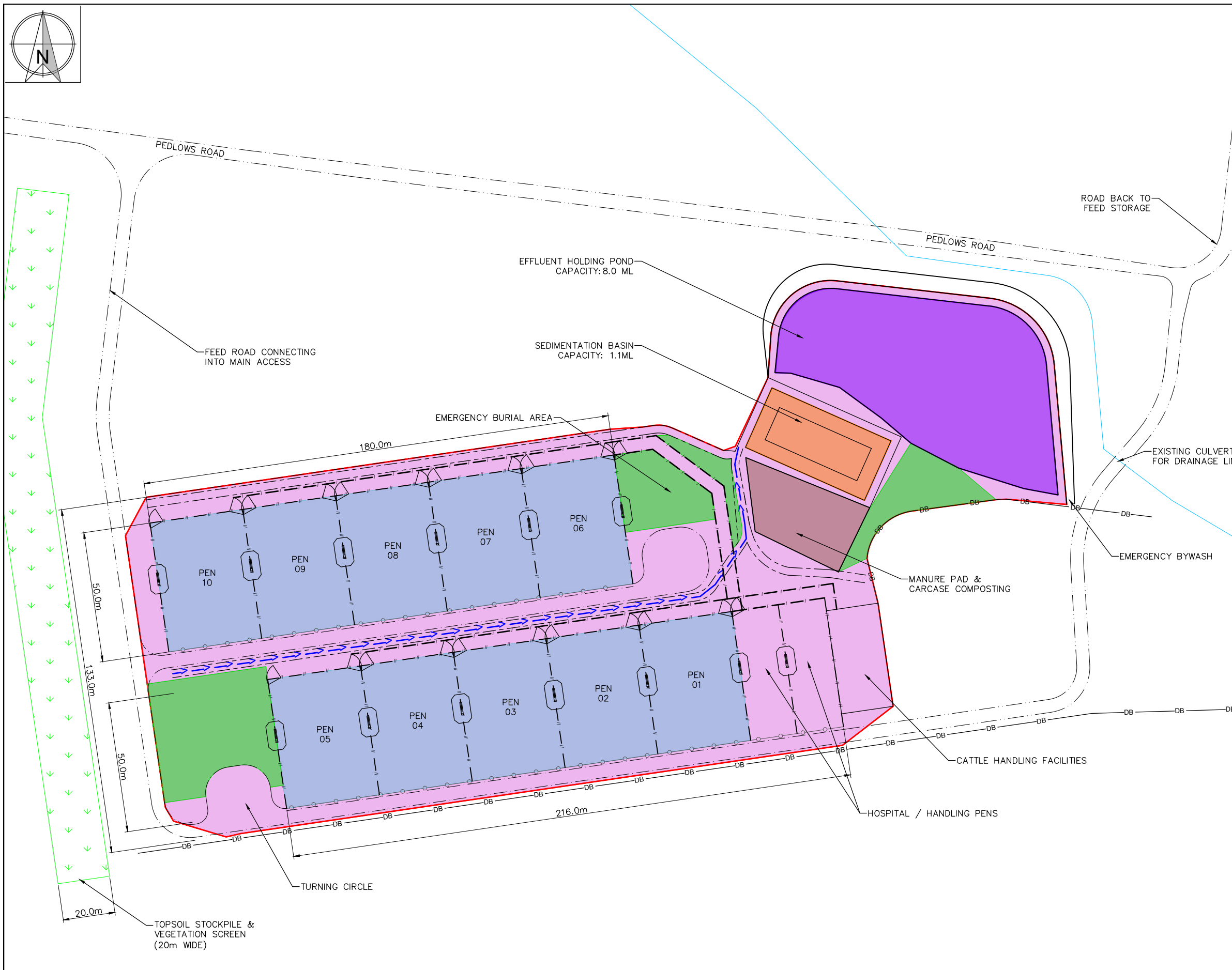

CLIENT
JARDANA PTY LTD

PROJECT
JARDANA FEEDLOT DEVELOPMENT

LOCATION
34 PEDLOWS ROAD, GLEN INNES NSW 2370

SHEET TITLE
CONTROLLED DRAINAGE AREA

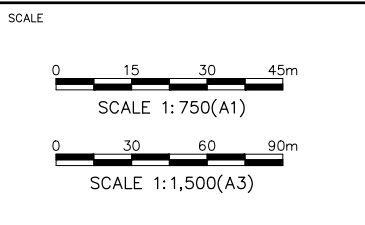

JARDANA PTY LTD

DESIGNED TJS	PRELIMINARY – FOR APPROVAL ONLY			JOB CODE PED-001
CHECKED MRN				SHEET NUMBER A005
PROJECT MANAGER MRN	06/10/2020	A	ORIGINAL ISSUE	CURRENT REVISION A
	DATE	REV	DESCRIPTION	REVISIONS

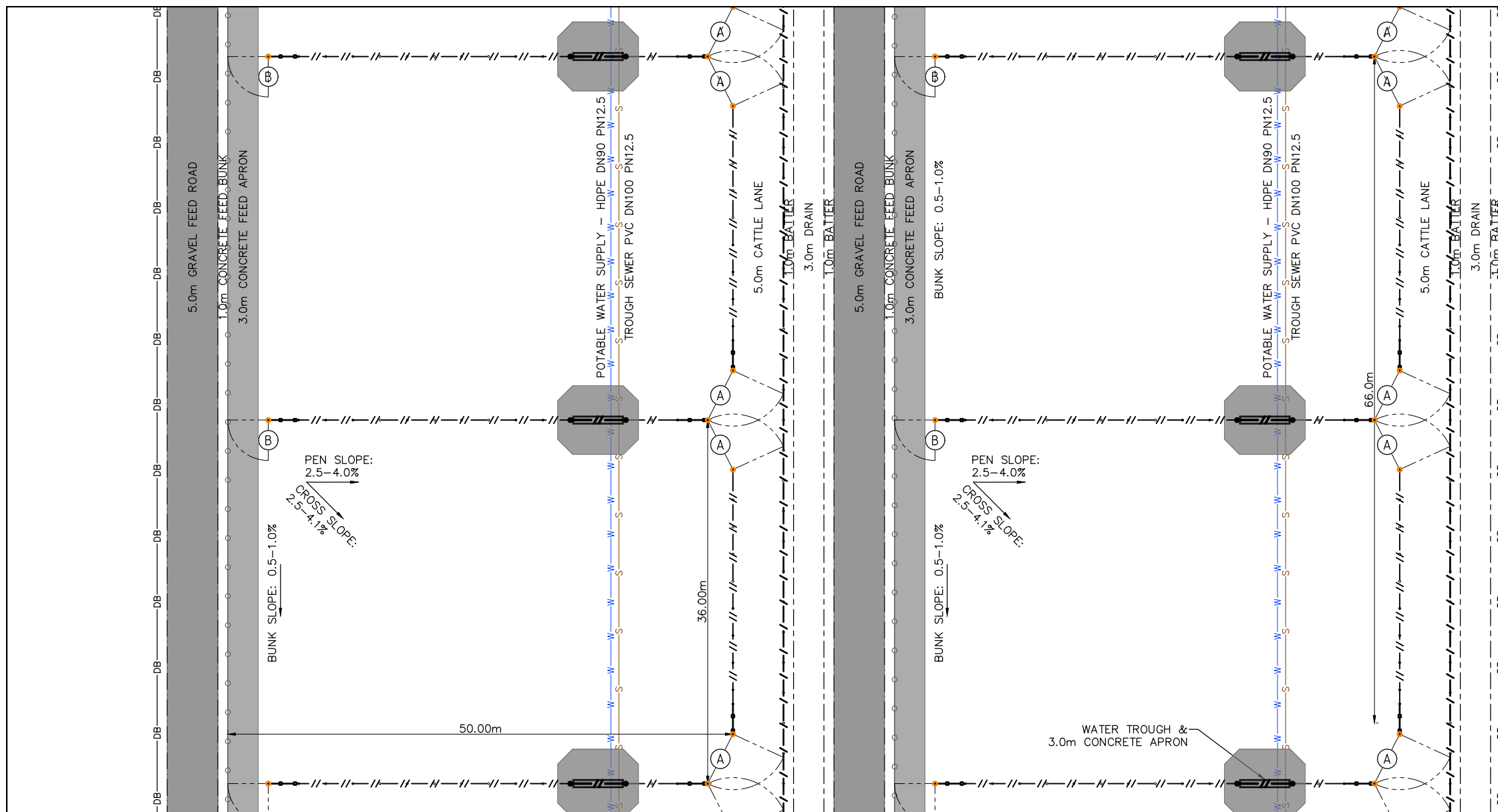

TYPICAL PLAN – PRODUCTION PENS

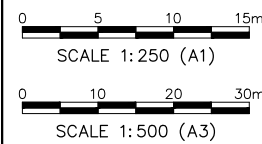

LEGEND – PROPOSED

- PEN FENCE
- RAIL STRAINER PANEL
- FEED BUNK
- EFFLUENT DRAIN
- FEED ROAD
- GATE – 5.5m CATTLE LANE ACCESS
- GATE – 4.0m PEN TO PEN ACCESS
- DRINKING WATER LINE
- TROUGH SEWER LINE

NOTES

1. THE PEN, DRAIN/BUNK & CROSS SLOPES PROVIDED IN THE DRAWING ARE A GENERAL RANGE ONLY. DESIGN SLOPES WILL BE FINALISED DURING THE DETAILED DESIGN PHASE. PEN GRADES WILL NOT VARY WITHIN PENS, RATHER BETWEEN THE ROWS TO BALANCE BULK EARTHWORKS AS REQUIRED.
2. THE FINAL SURFACE OF THE PAD MUST HAVE A MINIMUM CBR (CALIFORNIA BEARING RATIO) OF 20, AND BE OF SUFFICIENT DEPTH TO ENSURE THE INTEGRITY OF THE STRUCTURE IS MAINTAINED THROUGHOUT THE GENERAL WORKING OF THE FEEDLOT.
3. IRRESPECTIVE OF THE FINISHED PEN SURFACE, THE UNDERLYING SOILS MUST HAVE A MAXIMUM PERMEABILITY OF $1 \times 10^{-9} \text{m/s}$ (0.1mm/day) FOR DISTILLED WATER WITH 1.0m OF PRESSURE HEAD.
4. WHERE A CLAY LINER IS USED, THE MATERIAL SHOULD BE PLAYED IN LAYERS OF 150mm ($\pm 50 \text{mm}$). EACH LAYER SHOULD BE TINED, WETTED TO $\pm 2\%$ OF OPTIMUM MOISTURE CONTENT (AS 1289 5.1.1) AND COMPACTED TO REACH THE REQUIRED COMPACTION RELATIVE TO THE MAXIMUM DRY DENSITY (AS1289 5.4.2).

DESIGN: GENERAL FACILITY

1. FEED ROAD WIDTH = 5.0 m
2. BUNK WIDTH = 1.0 m
3. CATTLE LANE = 5.0 m
4. DRAIN WIDTH = 3.0 m

DESIGN: PRODUCTION PENS

1. STOCKING DENSITY = 18.0m²/SCU
2. BUNK SPACE = 360mm/SCU
3. PENS 36.0m x 50.0m = 1,800 m²/PEN
4. INDIVIDUAL PEN CAPACITY = 100 SCU
5. NEW PRODUCTION PENS = 10
6. CAPACITY = 1,000 SCU

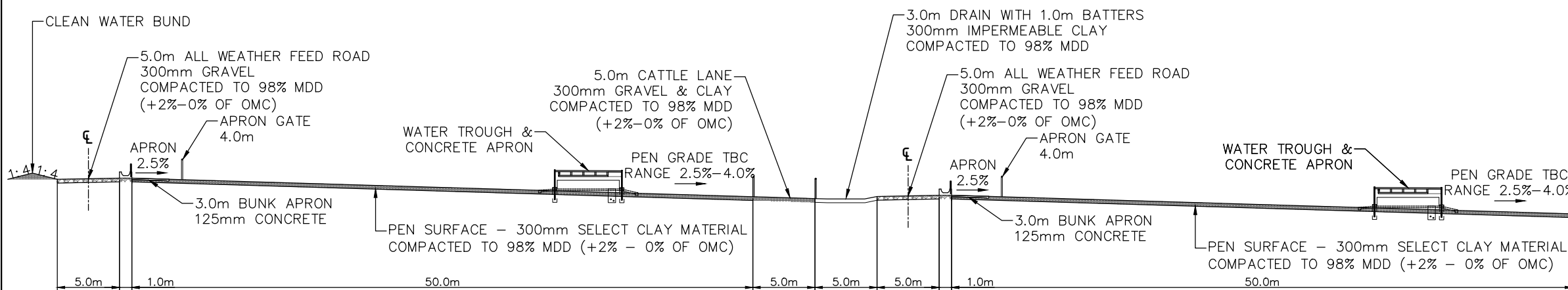

TYPICAL SECTION – PRODUCTION PENS

CLIENT
JARDANA PTY LTD

PROJECT
JARDANA FEEDLOT DEVELOPMENT

LOCATION
34 PEDLOWS ROAD, GLEN INNES NSW 2370

SHEET TITLE
TYPICAL PEN DESIGN

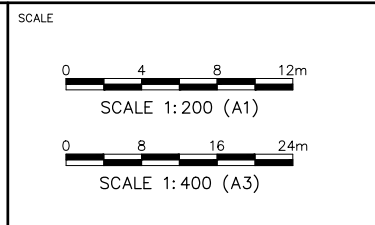

JARDANA PTY LTD

DESIGNED
TJS

CHECKED
MRN

PROJECT MANAGER
MRN

PRELIMINARY – FOR APPROVAL ONLY			
DATE	REV	DESCRIPTION	TJS
06/10/2020	A	ORIGINAL ISSUE	
REVISIONS			APP

JOB CODE
PED-001

SHEET NUMBER
A006

CURRENT REVISION
A

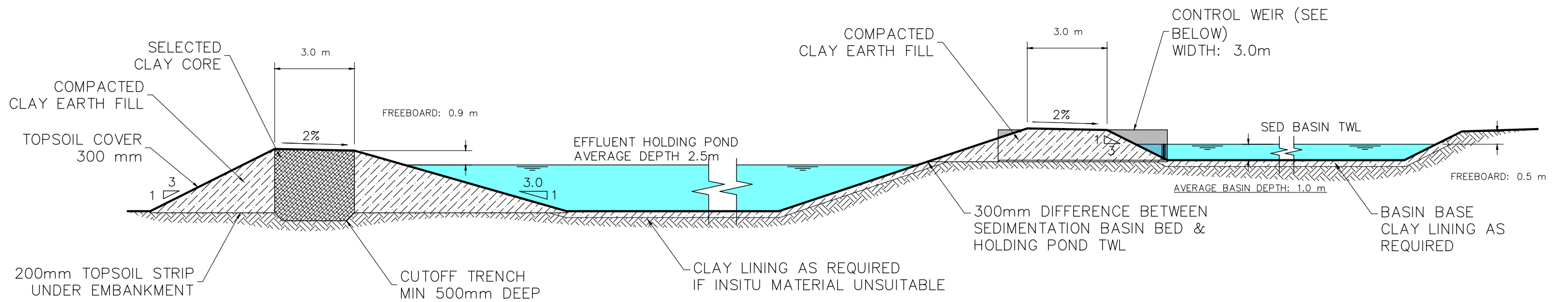

TYPICAL CROSS-SECTION: SEDIMENTATION BASIN AND HOLDING POND

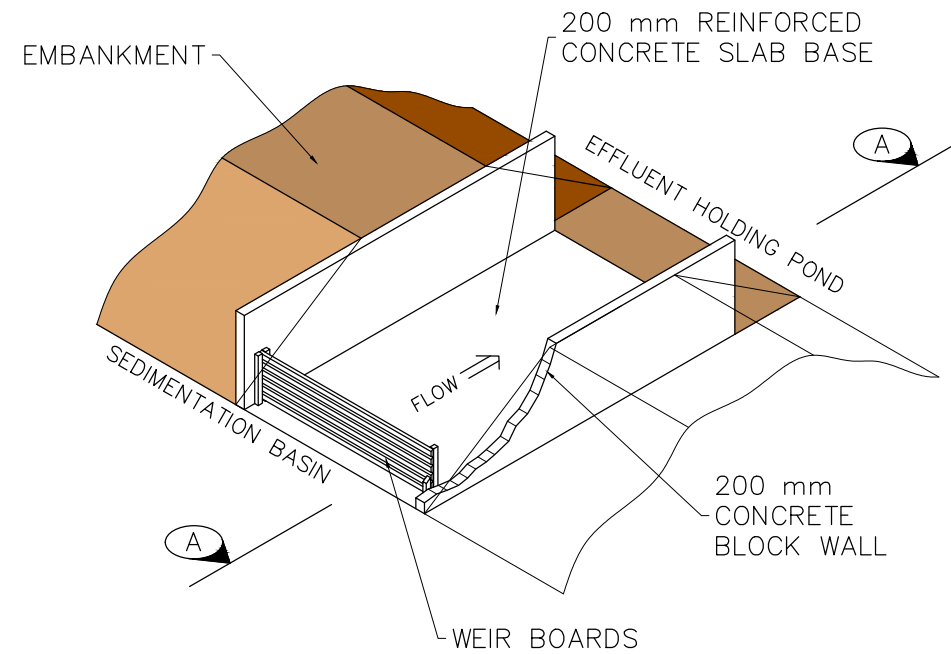

TYPICAL CONTROL WEIR

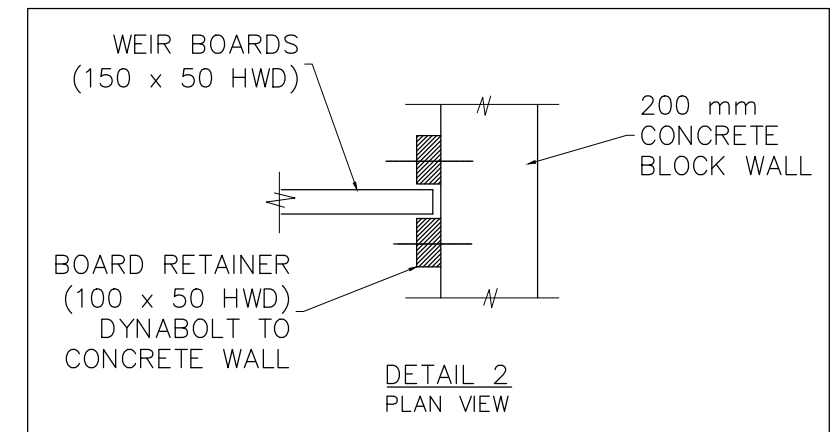
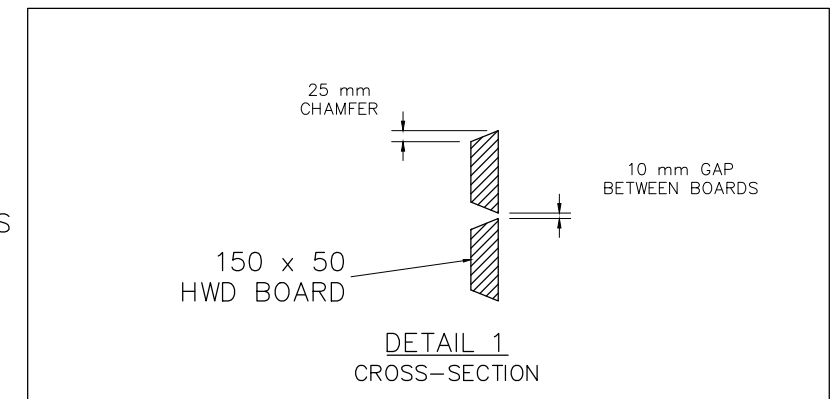
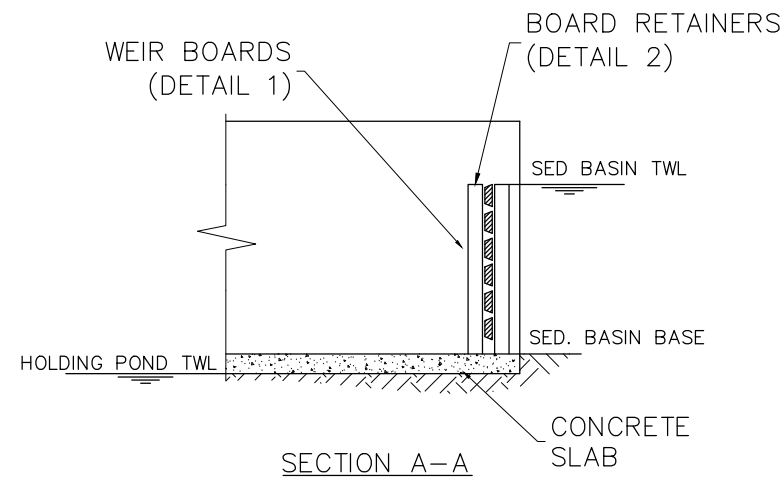

CLIENT
JARDANA PTY LTD
PROJECT
JARDANA FEEDLOT DEVELOPMENT
LOCATION
34 PEDLOWS ROAD, GLEN INNES NSW 2370
SHEET TITLE
TYPICAL SECTION - EFFLUENT MANAGEMENT SYSTEM

AgDSA
AGRICULTURAL DEVELOPMENT
SERVICES AUSTRALIA
PO BOX 292
TOOWOOMBA QLD 4350
PH: +61 418 446 245
E: contact@agdsa.com.au

SCALE
NOT TO SCALE

JARDANA
PTY LTD

DESIGNED
TJS
CHECKED
MRN
PROJECT MANAGER
MRN

PRELIMINARY - FOR APPROVAL ONLY

DATE	REV	DESCRIPTION	TJS	APP
06/10/2020	A	ORIGINAL ISSUE		

JOB CODE
PED-001
SHEET NUMBER
A007
CURRENT REVISION
A

APPENDIX B – SOIL INVESTIGATION

Soil Investigation

Jardana Feedlot Proposal

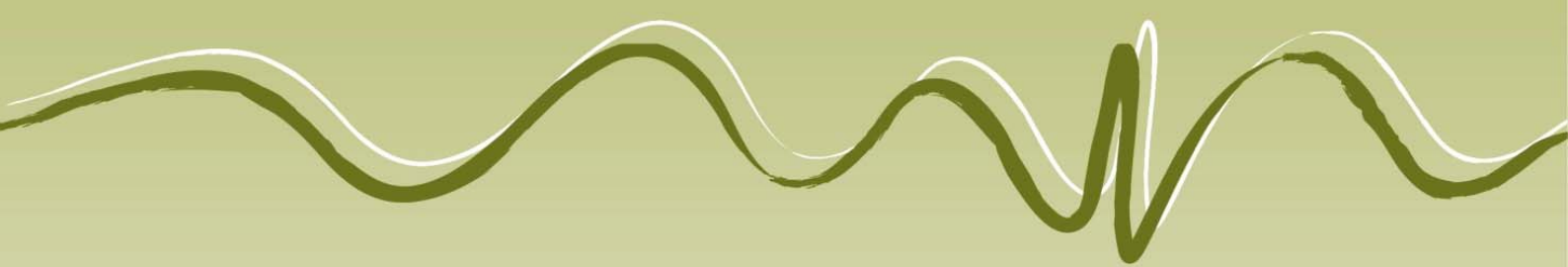

PO Box 119
Lennox Head NSW 2478
T 02 6687 7666

PO Box 1446
Coffs Harbour NSW 2450
T 02 6651 7666

PO Box 1267
Armidale NSW 2350
T 02 6772 0454

PO Box 229
Lismore NSW 2480
T 02 6621 6677

info@geolink.net.au

Prepared for: Owen Pedlow
© GeoLINK, 2019

<i>UPR</i>	<i>Description</i>	<i>Date Issued</i>	<i>Issued By</i>
3377-1004	First issue	09/08/2019	David Howley

Table of Contents

1.	Introduction	2
1.1	Site Description	2
1.2	Geology	2
1.3	Soils	2
2.	The Investigation	5
2.1	Feedlot Proposal	5
2.2	Soil Sampling	5
2.3	Results and Discussion	7
3.	Summary	8

Illustrations

Illustration 1.1	Topographic Map	3
Illustration 1.2	Soil Survey Locations	4

Tables

Table 2.1	Summary of Field Notes	6
-----------	------------------------	---

Plates

Plate 2.1	Pen Sample Site	6
Plate 2.2	Dam Sample Site	6
Plate 2.3	Irrigation Sample Site	6

Appendices

<u>Appendix A Chain of Custody</u>	
<u>Appendix B Laboratory Results</u>	

1. Introduction

GeoLINK have been engaged by Owen Pedlow to undertake an initial soil assessment to form part of a development application for a proposed intensive livestock operation (Jardana Feedlot Proposal). This investigation was associated with Lot 1 DP7243 and Lot 1 DP180562, 34 Pedlow Road, Stonehenge NSW. The zoning of the land is RU1 primary production. The broad aim of the investigation is to ascertain whether the soil on-site is suitable for an intensive livestock operation.

1.1 Site Description

The proposed 300-1000 head feedlot is located on private property in Stonehenge; a small township approximately 13 km south from Glen Innes. Refer to **Illustration 1.1** for site locality of the proposed feedlot, aerial and topographic information.

Three soil locations were sampled and tested. They are referred to as the pen, dam and irrigation area. Please refer to **Illustration 1.1 and 1.2** for their location and their context within the landscape. These three locations are referred to as the study area. Further description of the study area is provided within this section of the report.

The topography within the study area is characterised by slopes of 1.5 to 4 per cent, typically falling north and north-west. The proposed pen, holding dam and irrigation area are adjacent unnamed flow lines. These flow lines meander their way down to Beardy Waters some 1.8 km away. The elevation within the study area is between 1000 to 1100 m Australian Height Datum (AHD).

The nearest rural residence, the property owner's homestead, is located approximately 900 m north of the study area. The site access road is located approximately 50 m north known as Pedlows Road. This road provides access from the homestead to Stonehenge Road and then onto the New England Highway 2.4 km to the west.

The study area has been subject to extensive use and disturbance from previous farming activities and is free from significant stands of vegetation except for some mature trees that shall be retained. The land use is predominantly grazing with intermittent cultivation.

1.2 Geology

The study area falls within a transitional zone between granitic and basaltic geological origin. The pen site falls within the Wards Mistake Monzogranite of the lower Triassic period. The dam site, lower to the north, and the irrigation area, lower to the north-east, are within a basaltic origin area. These areas fall within the Central Province volcanics – alkaline basalt of the Oligocene period.

1.3 Soils

The soils within the study site reflect their geological origin. The pen area is a Red Earth with a thin basalt silty sand topsoil to a depth of 50 mm. Below that are red granite soils which are sandy clays to medium clays at depth to one metre, as sampled. The soils exhibit a low to moderate erodibility, they are hard backed at depth with no root presents. The dam and irrigation areas have a basalt silty sand topsoil to a depth of 100 mm and Black Earths of high plasticity to a depth of 1.4 m, as sampled. The soils exhibit a low to moderate erodibility.

Information shown is for illustrative purposes only

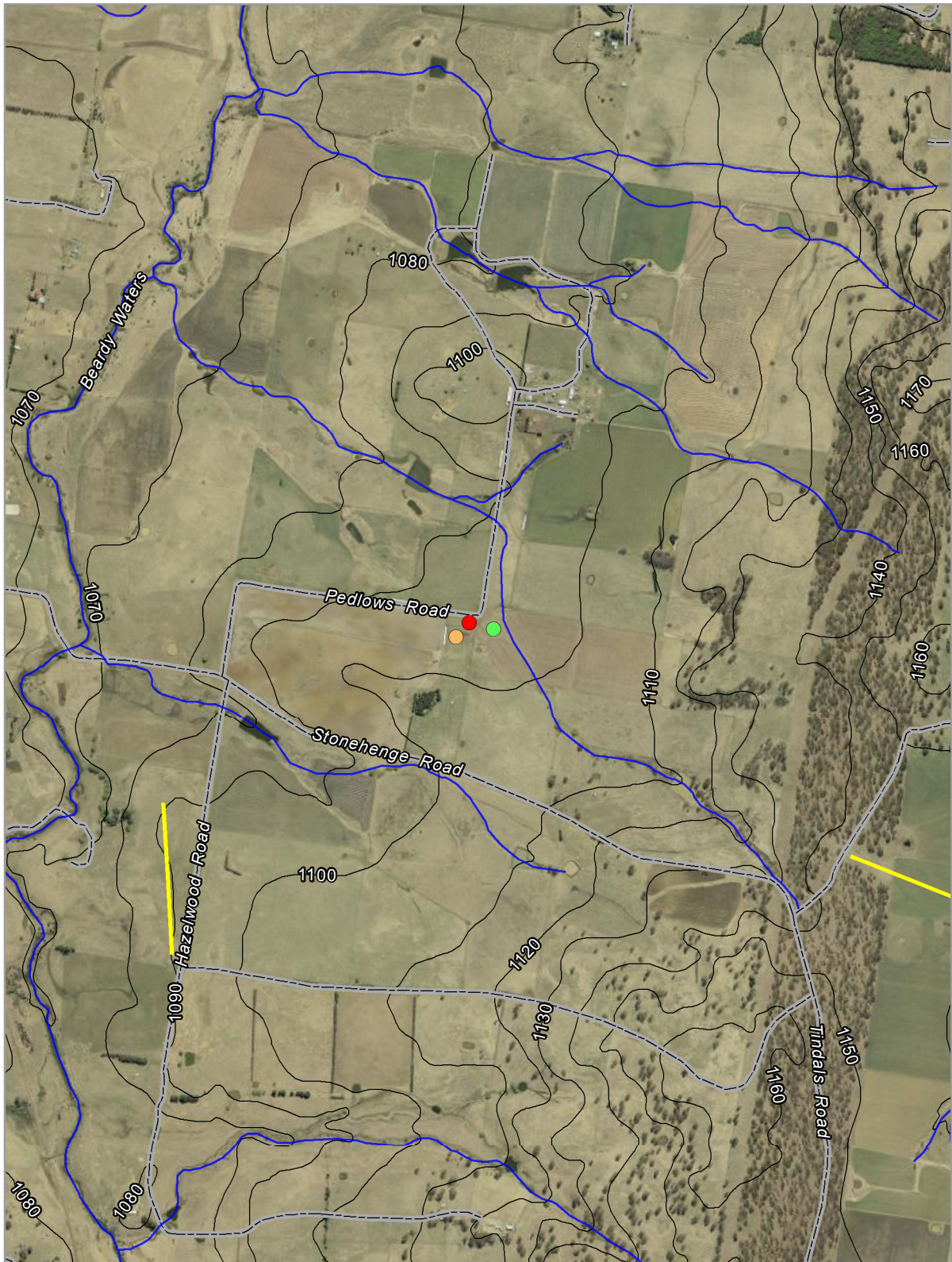

LEGEND

- Dam
- Irrigation
- Pen
- Contour at 10m intervals
- Watercourse
- Runway
- Road



Topographic Map





LEGEND

- Dam
- Irrigation
- Pen
-  Road



2. The Investigation

2.1 Feedlot Proposal

The feedlot is proposed to support agricultural production, particularly in drought conditions, and to support the maintenance of breeding stock. The feedlot pens will be in the vicinity of the pen soil sample location and further uphill to the south and south-west prior to granite rock outcrops. The pen area will be bound upslope by graded banks that will divert run-on waters away from the pen areas.

The dam soil sample area is a likely location for the holding dam. This will collect the runoff from the pen area and store water for a design storm event, runoff generated in a 90th percentile wet year. This water will be disposed of by evaporation and sustainable application for cropping and pasture to such areas as the irrigation area. The pen area will be bound downslope by graded banks (0.5 to 1 per cent) so that all pen runoff will be directed into the holding dam.

The water within the dam is to be kept at such a level that it has capacity to capture the design storm event runoff. To maintain the dam at such a level, water from the dam will be irrigated over the proposed irrigation area within the vicinity of the irrigation sample site. Run-on upslope of the irrigation area will be directed around the irrigation area to reduce the potential for nutrient flushing prior to plant uptake and use.

Cropping is intended to occur within the irrigation area. Such crops will include corn, barley, oats and sorghum. Other fodder crops may be grown dependant on the current climatic conditions and the enterprises requirements.

2.2 Soil Sampling

Soil sampling was conducted within three locations referred to as pen, dam and irrigation area. Please refer to **Illustration 1.2** for specific locations of the sample sites. Sampling involved:

- Drilling one hole (pen) with a post hole auger. Dam and irrigation sites were excavated with a dozer blade. No ground water was encountered.
- Sampling was undertaken by David Howley (Senior Environmental Engineer), GeoLINK.
- Samples were collected with a shovel. Sampling was undertaken using the quality assurance methodology. Prior to the site inspection, the equipment was thoroughly washed. To ensure there was no cross-contamination during the sampling procedure, the equipment was cleaned before each soil sample was taken.
- Samples were placed in zip lock plastic bags and within a 20 L plastic container.
- Seven samples were collected from the sample sites and the soils were sent under Chain of Custody conditions to East West Enviroag Pty Ltd Laboratory in Tamworth (refer to **Appendix A** for Chain of Custody documentation and **Appendix B** for laboratory results).

Table 2.1 Summary of Field Notes

Sample ID	Sample Depth (m)	Comments
Pen TS	0-0.05	Basalt silty sand topsoil
Pen SS	0.05-0.3	Granite sandy clay subsoil
Pen IS Clay	0.3-1.0	Granite hard packed medium clay subsoil
Dam	1.0-1.4	Basalt heavy clay subsoil
Irrigation TS	0-0.1	Basalt silty sand topsoil
Irrigation SS	0.1-0.4	Basalt medium to heavy clay
Irrigation Heavy Clay	0.4-0.7	Basalt heavy clay



Plate 2.1 Pen Sample Site



Plate 2.2 Dam Sample Site



Plate 2.3 Irrigation Sample Site

2.3 Results and Discussion

Refer to **Appendix B** for laboratory testing which shows parameters analysed for each sample and their values.

The pen area is dominated by medium clays (up to 700 mm deep as sampled) on slopes of around three per cent and potentially bounded by graded banks up to one per cent. These clays and slopes will limit effluent ingress into subsoils or groundwater. In addition, the bulk density, porosity of the soil and no plant root penetration indicates the soil is hard packed. With the addition of hooved animals this pen area will shed most of the rainfall that it receives.

In accordance with the National Guidelines for Beef Cattle Feedlots in Australia (2012) and Beef Cattle Feedlots: Design and Construction (2015), the sedimentation system, drains, manure windrow, mortality area and holding ponds are recommended to be underlain by at least 300 mm of clay or other suitable compactable soil. These areas are to be designed to provide a permeability of less than 1×10^{-9} m/s (~ 0.1 mm/d). A soil sample was taken from the proposed dam area to determine the permeability of the underlying clay soils. Soil test results demonstrated that the clay sitting at 1.0-1.4 m below the surface had a permeability of around 2.0×10^{-11} (refer to **Appendix B**). The dam area would therefore be excavated down to this clay layer and the dam walls would also be constructed of this material, providing a suitable low permeability layer such that effluent materials would not impact lower soil profile levels or groundwater.

It is suggested that, if the proposal was to proceed, ongoing surface water quality sampling and testing be undertaken from at least one dam close to the property boundary which would receive runoff from the proposal area. This sampling should commence prior to the proposal occurring and during the proposal operation on a six-monthly basis. The parameters to test for would be best prescribed by the Local and State Authorities. Refer to Department of Environment and Conservation (DEC) 2004 for guidance.

The irrigation area is intended to be used to receive water from the holding dam. It has a slope of around 1.5-2 per cent and has been used for cropping in the past. When sampled the site had recently been cultivated. This area at depth also had low permeability soils, as the dam area, to 700 mm as sampled. This will limit ingress of effluent into lower soil profiles or groundwater. The soil profiles above were more porous allowing root penetration and water uptake potential. The bulk density and porosity results confirm such conditions. These soils have good levels of trace elements to support plant grow. The pH values of the topsoil are suitable for the crops proposed.

The electrical conductivity (salinity) of the soil is low supportive of plant grow. The soils have low sodicity meaning they are stable soils which allow water infiltration and plant root penetration. The effective cation exchange capacity ECEC is high indicating that the soil has capacity to uptake and store nutrients and mitigate other changes to the soils properties due to effluent irrigation. The Phosphorous buffering index and Phosphorous (Colwell) indicates that the soil can make available phosphorus for plant production and it has potential for phosphorus storage.

The irrigation area overall appears to be a suitable site for effluent irrigation. In any irrigation area, especially effluent, regular soil monitoring regimes are recommended to ascertain whether nutrient levels, compounds and elements are staying within base line conditions. Refer to DEC 2004 for suggested monitoring frequency and parameters. The removal of crops from the site will help to balance out nutrient levels over time and would form part of an overall irrigation strategy.

3. Summary

Based on the site inspection and soil testing, the soils within the three sites sampled and tested appear to be suitable for the proposed development. The pen area had suitable slope and medium hard packed clays for animal concentration. The holding dam soil was shown to have low permeability suitable for storing effluent water and the irrigation area had capacity to uptake and store nutrients for crop and fodder production. The irrigation area also possessed low permeability heavy clays to limit water infiltration into soils at depth.

With any such proposal, monitoring of both the soil and surface water would be critical to ensure that the balance of nutrients, compounds and elements are staying consistent with the environment prior to the proposal occurring. An overall irrigation strategy, including crop removal, would also be critical to maintaining baseline environmental parameters.

References

Department of Environment and Conservation, DEC, (2004), [Now the NSW Office of Environment and Heritage, OEH]. *Use of Effluent by Irrigation*. Sydney South.

Meat & Livestock Australia (2015). *Beef Cattle Feedlots: Design and Construction*, Level 1, 40 Mount Street. North Sydney.

Meat & Livestock Australia (2012). *National Guidelines for Beef Cattle Feedlots in Australia*, Level 1, 40 Mount Street. North Sydney.

Copyright and Usage

©GeoLINK, 2019

This document, including associated illustrations and drawings, was prepared for the exclusive use of Owen Pedlow. It is not to be used for any other purpose or by any other person, corporation or organisation without the prior consent of GeoLINK. GeoLINK accepts no responsibility for any loss or damage suffered howsoever arising to any person or corporation who may use or rely on this document for a purpose other than that described above.

This document, including associated illustrations and drawings, may not be reproduced, stored, or transmitted in any form without the prior consent of GeoLINK. This includes extracts of texts or parts of illustrations and drawings.

The information provided on illustrations is for illustrative and communication purposes only. Illustrations are typically a compilation of data supplied by others and created by GeoLINK. Illustrations have been prepared in good faith, but their accuracy and completeness are not guaranteed. There may be errors or omissions in the information presented. In particular, illustrations cannot be relied upon to determine the locations of infrastructure, property boundaries, zone boundaries, etc. To locate these items accurately, advice needs to be obtained from a surveyor or other suitably-qualified professional.

The dimensions, number, size and shape of lots shown on drawings are subject to detailed engineering design, final survey and Council conditions of consent.

Topographic information presented on the drawings is suitable only for the purpose of the document as stated above. No reliance should be placed upon topographic information contained in this report for any purpose other than that stated above.

Appendix A

Chain of Custody



CHAIN OF CUSTODY – Client
EAST WEST – 02 6762 1733

East West
82 Plain St
Tamworth NSW 2340

Client: GeoLINK

Client Project Name / Number / Site etc (ie report title): GI

Contact Person: David Howley

Project Mgr: As above

PO No:

Sampler: As above

East West Quote Number:

Address: GeoLINK 146 Beardy Street Armidale NSW 2350

Date results required:
Standard
 Or choose: Standard / 5 day
Note: Inform lab in advance if urgent turnaround is required – surcharges apply.

T 02 6762 1733

F 02 6765 9109

E admin@eastwestonline.com.au

W www.eastwestonline.com.au

Phone: Mobile: 0457 363 755

Lab comments: Samples picked up in Armidale by EW.

Email: dhowley@geolink.net.au

Sample Information					Tests Required									Comments
East West Sample ID	Client Sample ID or information	Depth	Date Sampled	Type of Sample	Dispersion % & Gypsum requirement	EC	pH	EAT	PSA	Permeability with Compaction (TriLab)	SHC	PI (4pts)	LS	
	Dam	1-1.4	22/05/19	Soil / Clay	1	1	1	1	1	1	1	1	1	Provide as much information about the sample as you can

Relinquished by (Company): GeoLINK given to EW in Armidale

Received by (Company):

Lab use only:
 Samples received: Cool or Ambient
 Temperature Received at:
 Transported by: Hand delivered / Courier

Print Name: David Howley

Print Name:

Date and Time: 23/05/19

Date and Time:

Signature: CoC Via email

Signature:



CHAIN OF CUSTODY – Client
EAST WEST – 02 6762 1733

East West
82 Plain St
Tamworth NSW 2340

Client: GeoLINK

Client Project Name / Number / Site etc (ie report title): GI

Contact Person: David Howley

Project Mgr: As above

PO No:

Sampler: As above

East West Quote Number:

Address: GeoLINK 146 Beardy Street Armidale NSW 2350

Date results required:
Standard
 Or choose: Standard / 5 day
Note: Inform lab in advance if urgent turnaround is required – surcharges apply.

T 02 6762 1733
F 02 6765 9109
E admin@eastwestonline.com.au
W www.eastwestonline.com.au

Phone: Mobile: 0457 363 755

Lab comments: Samples picked up in Armidale by EW.

Email: dhowley@geolink.net.au

Require results for SHC and PSA

Sample Information					Tests Required										Comments	
East West Sample ID	Client Sample ID or information	Depth	Date Sampled	Type of Sample	S1	PAWC	Total N	Phos Buffer index	USCS	Bulk Density Porosity						Provide as much information about the sample as you can
	Pen	0-0.05	22/05/19	TS	1	1	1	1	1	1						Basalt TS
	Pen	0.05-0.3	22/05/19	SS	1	1	1	1	1	1						Basalt SS
	Pen	0.3-1.0	22/05/19	IS Clay	1	1	1	1	1	1						Iron stone clay
	Irrigation	0-0.1	22/05/19	TS	1	1	1	1	1	1						Basalt TS
	Irrigation	0.1-0.4	22/05/19	SS	1	1	1	1	1	1						Basalt subsoil
	Irrigation	0.4-0.7	22/05/19	Heavy Clay	1	1	1	1	1	1						Heavy Basalt clay

Relinquished by (Company): GeoLINK given to EW in Armidale

Received by (Company):

Lab use only:
 Samples received: Cool or Ambient
 Temperature Received at:
 Transported by: Hand delivered / Courier

Print Name: David Howley

Print Name:

Date and Time: 23/05/19

Date and Time:

Signature: CoC Via email

Signature:

Appendix B

Laboratory Results



eastwest
geo ag enviro

82 Plain Street Tamworth NSW 2340
e admin@eastwestonline.com.au
t 02 6762 1733
f 02 6765 9109
abn 82 125 442 382

eastwestonline.com.au 

ANALYSIS REPORT SOIL

PROJECT NO: EW190971

Date of Issue: 06/06/2019

Customer: GEOLINK

Report No: 1

Address: 146 Beardy St ARMIDALE NSW 2350

Date Received: 27/05/2019

Matrix: Soil

Attention: David Howley

Location: Dam

Phone: 0457 363 755

Sampler ID: Client

Fax:

Date of Sampling: 22/05/2019

Email: dhowley@geolink.net.au

Sample Condition: Acceptable

Results apply to the samples as submitted. All pages of this report have been checked and approved for release.

Signed: Anne Michie



East West is certified by the Australian-Asian Soil & Plant Analysis Council to perform various soil and plant tissue analysis. The tests reported herein have been performed in accordance with our terms of accreditation.

This report must not be reproduced except in full and EWEA takes no responsibility of the end use of the results within this report.

This analysis relates to the sample submitted and it is the client's responsibility to make certain the sample is representative of the matrix to be tested.

Samples will be discarded one month after the date of this report. Please advise if you wish to have your sample/s returned.

results you can rely on



eastwest
geo ag enviro

82 Plain Street Tamworth NSW 2340
e admin@eastwestonline.com.au
t 02 6762 1733
f 02 6765 9109
abn 82 125 442 382

eastwestonline.com.au 

ANALYSIS REPORT SOIL

PROJECT NO: EW190972	Date of Issue: 06/06/2019
Customer: GEOLINK	Report No: 1
Address: 146 Beardy St ARMIDALE NSW 2350	Date Received: 27/05/2019
Attention: David Howley	Matrix: Soil
Phone: 0457 363 755	Location:
Fax:	Sampler ID: Client
Email: dhowley@geolink.net.au	Date of Sampling: 22/05/2019
	Sample Condition: Acceptable

Results apply to the samples as submitted. All pages of this report have been checked and approved for release.

Signed: Anne Michie



East West is certified by the Australian-Asian Soil & Plant Analysis Council to perform various soil and plant tissue analysis. The tests reported herein have been performed in accordance with our terms of accreditation.

This report must not be reproduced except in full and EWEA takes no responsibility of the end use of the results within this report.

This analysis relates to the sample submitted and it is the client's responsibility to make certain the sample is representative of the matrix to be tested.

Samples will be discarded one month after the date of this report. Please advise if you wish to have your sample/s returned.

results you can rely on



ANALYSIS REPORT

PROJECT NO: EW190972

Location:

CLIENT SAMPLE ID					Pen TS	Pen SS	Pen IS Clay	Irrigation TS
					0-0.05	0.05-0.3	0.3-1.0	0-0.1
DEPTH								
Test Parameter	Method Description	Method Reference	Units	LOR	190972-1	190972-2	190972-3	190972-4
Plant Available Water Capacity	Shaw & Yule	24.4.1	mm/m	na	100.9	58.1	28.4	142.4
PAWC (gravimetric)	Shaw & Yule	24.4.1	%	na	10.1	5.81	2.84	14.24
WMAX Field capacity	Shaw & Yule	24.4.1	%	na	23.49	14.17	13.53	30.78
WMIN Wilting Point	Shaw & Yule	24.4.1	%	na	13.40	8.36	10.69	16.54
pH (1:5 in CaCl ₂)	Electrode	R&L4B2	pH units	na	5.06	4.98	4.70	5.65
Chloride Soluble	Electrode	PMS-05	mg/kg	2	45.0	92.1	24.1	22.6
Electrical Conductivity	Electrode	R&L 3A1	dS/m	0.01	0.18	0.20	0.04	0.19
Total N (LECO)	LECO	R&L 7A5	mg/kg	50	4589	1656	630	3232
Extractable Nitrate-N	H2O/UV-Vis	PMS-08	mg/kg	0.5	12.2	18.9	1.89	18.1
Organic Carbon (LECO)	LECO	R&L 6B3	%	0.05	2.76	1.43	0.95	2.65
Phosphorus Buffer Index	UV-Vis	PMS-12	mg/kg	na	110	76.5	258	150
Phosphorus (Colwell)	Bicarb/UV-Vis	R&L 9B1	mg/kg	1	241	32.5	15.5	90.5
Sulphate-Sulphur	KCl40/ICP	R&L 10D1	mg/kg	3	24.9	42.6	7.80	51.1
Extractable Copper	DTPA/ICP	R&L 12A1	mg/kg	0.2	0.97	0.75	0.47	2.37
Extractable Zinc	DTPA/ICP	R&L 12A1	mg/kg	0.2	3.19	0.34	0.25	0.79
Extractable Manganese	DTPA/ICP	R&L 12A1	mg/kg	0.5	28.8	43.6	6.84	31.9
Extractable Iron	DTPA/ICP	R&L 12A1	mg/kg	0.5	494	179	37.8	83.3
Exchangeable Potassium	NH ₄ Cl/ICP	R&L 15A1	mg/kg	10	498	68.0	44.3	266
Exchangeable Calcium	NH ₄ Cl/ICP	R&L 15A1	mg/kg	20	1174	692	473	5137
Exchangeable Magnesium	NH ₄ Cl/ICP	R&L 15A1	mg/kg	10	336	164	307	1654
Exchangeable Sodium	NH ₄ Cl/ICP	R&L 15A1	mg/kg	10	92.0	105	177	101
Exchangeable Aluminium	KCl/ICP	R&L 15G1	mg/kg	1	3.2	6.53	8.41	<1.0
Exchangeable Potassium	R&L 15A1	R&L 15A1	cmol/kg	na	1.28	0.17	0.11	0.68
Exchangeable Calcium	R&L 15A1	R&L 15A1	cmol/kg	na	5.87	3.46	2.37	25.7
Exchangeable Magnesium	R&L 15A1	R&L 15A1	cmol/kg	na	2.80	1.37	2.56	13.8
Exchangeable Sodium	R&L 15A1	R&L 15A1	cmol/kg	na	0.40	0.46	0.77	0.44





ANALYSIS REPORT

PROJECT NO: EW190972

Location:

CLIENT SAMPLE ID					Pen TS	Pen SS	Pen IS Clay	Irrigation TS
					0-0.05	0.05-0.3	0.3-1.0	0-0.1
DEPTH					190972-1	190972-2	190972-3	190972-4
Test Parameter	Method Description	Method Reference	Units	LOR	190972-1	190972-2	190972-3	190972-4
Exchangeable Aluminium	Calculation	R&L 15J1	cmol/kg	na	0.04	0.07	0.09	0.01
ECEC	Calculation	PMS-15A1	cmol/kg	na	10.4	5.53	5.90	40.6
Ca/Mg Ratio	Calculation	PMS-15A1	cmol/kg	na	2.10	2.53	0.92	1.86
K/Mg Ratio	Calculation	PMS-15A1	cmol/kg	na	0.46	0.13	0.04	0.05
Exchangeable Potassium %	Calculation	PMS-15A1	%	na	12.3	3.15	1.93	1.68
Exchangeable Calcium %	Calculation	PMS-15A1	%	na	56.5	62.6	40.1	63.3
Exchangeable Magnesium %	Calculation	PMS-15A1	%	na	27.0	24.7	43.4	33.9
Exchangeable Sodium %	Calculation	PMS-15A1	%	na	3.85	8.26	13.0	1.08
Exchangeable Aluminium %	Calculation	PMS-15A1	%	na	0.34	1.31	1.58	0.03
Texture	Field	USCS	Class	na	SM	SC	CL	CH
Bulk Density	Recompacted	AS 4454	kg/L	na	1.0	1.5	1.5	1.2
Porosity Total	Calc	ASTM F1815-97	%	na	49.7	33.5	39.0	45.3





ANALYSIS REPORT

PROJECT NO: EW190972

Location:

CLIENT SAMPLE ID					Irrigation SS	Irrigation Heavy Clay		
					0.1-0.4	0.4-0.7		
DEPTH								
Test Parameter	Method Description	Method Reference	Units	LOR	190972-5	190972-6		
Plant Available Water Capacity	Shaw & Yule	24.4.1	mm/m	na	100.9	72.8		
PAWC (gravimetric)	Shaw & Yule	24.4.1	%	na	10.0	7.28		
WMAX Field capacity	Shaw & Yule	24.4.1	%	na	38.11	51.29		
WMIN Wilting Point	Shaw & Yule	24.4.1	%	na	28.02	44.01		
pH (1:5 in CaCl ₂)	Electrode	R&L4B2	pH units	na	6.75	6.39		
Chloride Soluble	Electrode	PMS-05	mg/kg	2	5.26	2.34		
Electrical Conductivity	Electrode	R&L 3A1	dS/m	0.01	0.06	0.06		
Total N (LECO)	LECO	R&L 7A5	mg/kg	50	667	1583		
Extractable Nitrate-N	H2O/UV-Vis	PMS-08	mg/kg	0.5	3.42	2.45		
Organic Carbon (LECO)	LECO	R&L 6B3	%	0.05	0.53	1.46		
Phosphorus Buffer Index	UV-Vis	PMS-12	mg/kg	na	194	483		
Phosphorus (Colwell)	Bicarb/UV-Vis	R&L 9B1	mg/kg	1	11.3	12.4		
Sulphate-Sulphur	KCl40/ICP	R&L 10D1	mg/kg	3	8.11	8.61		
Extractable Copper	DTPA/ICP	R&L 12A1	mg/kg	0.2	1.21	2.41		
Extractable Zinc	DTPA/ICP	R&L 12A1	mg/kg	0.2	<0.20	<0.20		
Extractable Manganese	DTPA/ICP	R&L 12A1	mg/kg	0.5	5.43	4.29		
Extractable Iron	DTPA/ICP	R&L 12A1	mg/kg	0.5	24.2	44.5		
Exchangeable Potassium	NH ₄ Cl/ICP	R&L 15A1	mg/kg	10	120	202		
Exchangeable Calcium	NH ₄ Cl/ICP	R&L 15A1	mg/kg	20	4560	6142		
Exchangeable Magnesium	NH ₄ Cl/ICP	R&L 15A1	mg/kg	10	1553	2455		
Exchangeable Sodium	NH ₄ Cl/ICP	R&L 15A1	mg/kg	10	101	218		
Exchangeable Aluminium	KCl/ICP	R&L 15G1	mg/kg	1	<1.0	<1.0		
Exchangeable Potassium	R&L 15A1	R&L 15A1	cmol/kg	na	0.31	0.52		
Exchangeable Calcium	R&L 15A1	R&L 15A1	cmol/kg	na	22.8	30.7		
Exchangeable Magnesium	R&L 15A1	R&L 15A1	cmol/kg	na	12.9	20.5		
Exchangeable Sodium	R&L 15A1	R&L 15A1	cmol/kg	na	0.44	0.95		





ANALYSIS REPORT

PROJECT NO: EW190972

Location:

CLIENT SAMPLE ID					Irrigation SS	Irrigation Heavy Clay		
					0.1-0.4	0.4-0.7		
DEPTH								
Test Parameter	Method Description	Method Reference	Units	LOR	190972-5	190972-6		
Exchangeable Aluminium	Calculation	R&L 15J1	cmol/kg	na	0.01	0.01		
ECEC	Calculation	PMS-15A1	cmol/kg	na	36.5	52.6		
Ca/Mg Ratio	Calculation	PMS-15A1	cmol/kg	na	1.76	1.50		
K/Mg Ratio	Calculation	PMS-15A1	cmol/kg	na	0.02	0.03		
Exchangeable Potassium %	Calculation	PMS-15A1	%	na	0.84	0.98		
Exchangeable Calcium %	Calculation	PMS-15A1	%	na	62.5	58.3		
Exchangeable Magnesium %	Calculation	PMS-15A1	%	na	35.5	38.9		
Exchangeable Sodium %	Calculation	PMS-15A1	%	na	1.20	1.80		
Exchangeable Aluminium %	Calculation	PMS-15A1	%	na	0.03	0.02		
Texture	Field	USCS	Class	na	CH	CH		
Bulk Density	Recompacted	AS 4454	kg/L	na	1.2	1.0		
Porosity Total	Calc	ASTM F1815-97	%	na	44.7	49.5		

This Analysis Report shall not be reproduced except in full without the written approval of the laboratory.

NB: LOR is the Lowest Obtainable Reading.

DOCUMENT END





ANALYSIS REPORT

PROJECT NO: EW190971

Location: Dam

					CLIENT SAMPLE ID	Dam- Clay Soil			
					DEPTH	1-1.4			
Test Parameter	Method Description	Method Reference	Units	LOR	190971-1				
pH (1:5 in H2O)	Electrode	R&L 4A2	pH units	na	8.06				
Electrical Conductivity	Electrode	R&L 3A1	dS/m	0.01	0.19				
Saturated Hydraulic Conductivity	30cm tension	ASTM F1815-97	mm/hr	0.1	2.4				
Emerson Aggregate Test	Class	PMS-21	Number	na	4				
Gravel >2.0mm	Sieve	ASTMD422-63	%	na	3.9				
Coarse Sand 0.2-2.0mm	Sieve	ASTMD422-63	%	na	12.9				
Fine Sand 0.02-0.2mm	Sieve	ASTMD422-63	%	na	11.2				
Silt 0.002-0.02mm	Hydrometer	ASTMD422-63	%	na	5.4				
Clay <0.002mm	Hydrometer	ASTMD422-63	%	na	66.6				

This Analysis Report shall not be reproduced except in full without the written approval of the laboratory.

NB: LOR is the Lowest Obtainable Reading.

DOCUMENT END



PERMEABILITY BY CONSTANT HEAD TEST REPORT

Test Method AS 1289 6.7.3, 5.1.1

Client East West Enviroag Pty Ltd	Report No. 19060109-CHP
Address 82 Plain Street, Tamworth NSW 2340	Workorder No. 0006047
Project Proposed Compost Pad	Test Date 17/06/2019
Client ID 190971-1	Report Date 28/06/2019
Description SILTY CLAY - dark brown/grey	Depth (m) 1.00-1.40
	Sample Type Remoulded Soil Specimen.

RESULTS OF TESTING

Compaction Method	AS1289.5.1.1 - Standard Compaction		
Maximum Dry Density (t/m ³)	1.35	Confining Pressure (kPa)	525
Optimum Moisture Content (%)	31.8	Inlet Pressure/Outlet Pressure (kPa)	450 / 400
Placement Moisture Content (%)	32.0	Mean Effective Stress (kPa)	100
Moisture Ratio (%)	100.8	Water Type	De-Ionized
Placement Wet Density (t/m ³)	1.74	Percentage Material Retained/Sieve Size (mm)	0 % / 4.75 mm
Density Ratio (%)	97.7	Sample Height and Diameter (mm)	59.4 / 47.5 mm

PERMEABILITY $k_{(20)} = 2.0 \times 10^{-11}$ (m/sec)

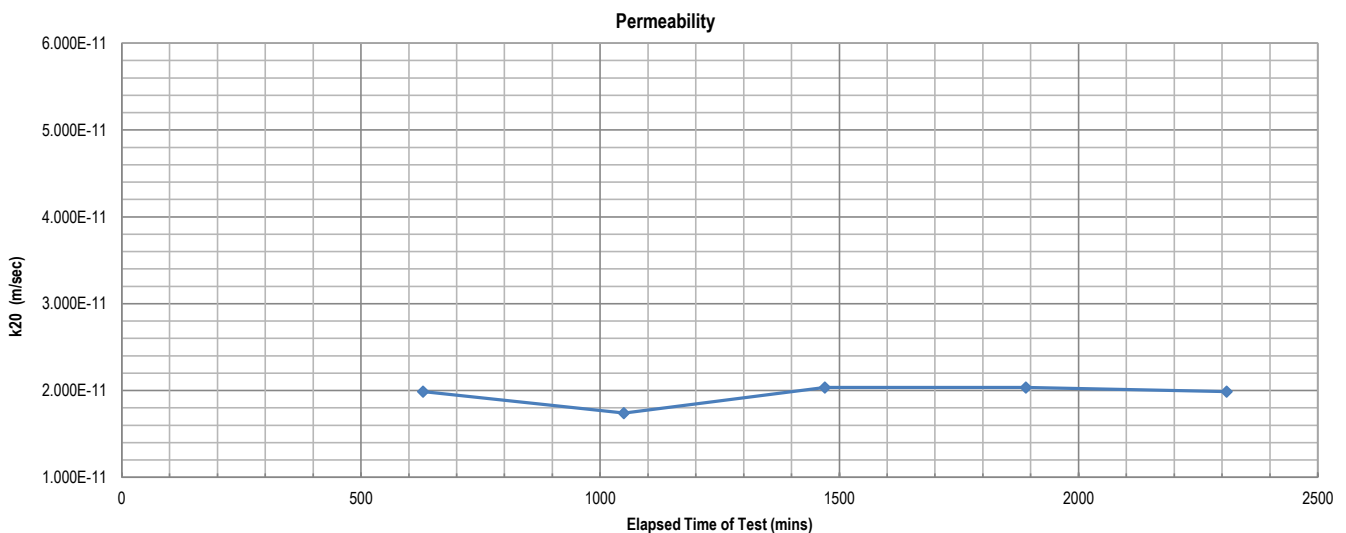

Remarks: The above specimen was remoulded to a target of 98% of Standard Maximum Dry Density and at Optimum Moisture Content.

Sample/s supplied by client

Page: 1 of 1

REP06502

Accredited for compliance with ISO/IEC 17025 - Testing.
The results of the tests, calibrations, and/or measurements included in this document are traceable to Australian/National Standards.

Tested at Trilab Brisbane Laboratory

Authorised Signatory



T. Lockhart



Laboratory No. 9926

The results of calibrations and tests performed apply only to the specific instrument or sample at the time of test unless otherwise clearly stated.

Reference should be made to Trilab's "Standard Terms and Conditions of Business" for further details.

Trilab Pty Ltd ABN 25 065 630 506

ACCURATE QUALITY RESULTS FOR TOMORROW'S ENGINEERING

APPENDIX C – GROUNDWATER WORKS SUMMARY

WaterNSW

Work Summary

GW965621

Licence:

Licence Status:

Authorised Purpose(s):

Intended Purpose(s): STOCK, DOMESTIC

Work Type: Bore

Work Status:

Construct.Method: Percussion

Owner Type:

Commenced Date:

Completion Date: 10/10/2002

Final Depth: 33.00 m

Drilled Depth: 33.00 m

Contractor Name: Mannion Drilling Pty Ltd

Driller: Jason Roger Mannion

Assistant Driller:

Property:

Standing Water Level
(m):

GWMA:

Salinity Description:

GW Zone:

Yield (L/s):

Site Details

Site Chosen By:

County
Form A: GOUGH
Licensed:

Parish
STONEHENGE

Cadastre
LT 1 DP 169052

Region: 90 - Barwon

CMA Map:

River Basin: - Unknown
Area/District:

Grid Zone:

Scale:

Elevation: 0.00 m (A.H.D.)
Elevation Source: Unknown

Northing: 6702026.000
Easting: 380362.000

Latitude: 29°48'23.0"S
Longitude: 151°45'43.2"E

GS Map: -

MGA Zone: 56

Coordinate Source: Map Interpre

Construction

Negative depths indicate Above Ground Level; C-Cemented; SL-Slot Length; A-Aperture; GS-Grain Size; Q-Quantity; PL-Placement of Gravel Pack; PC-Pressure Cemented; S-Sump; CE-Centralisers

Hole	Pipe	Component	Type	From (m)	To (m)	Outside Diameter (mm)	Inside Diameter (mm)	Interval	Details
1		Hole	Hole	0.00	33.00	165			Percussion
1	1	Casing	Pvc Class 9	0.00	33.00	152	141		Seated on Bottom, Glued
1	1	Opening	Slots - Diagonal	16.00	27.00	152		0	Mechanically Slotted, PVC Class 9, SL: 100.0mm, A: 2.00mm

Water Bearing Zones

From (m)	To (m)	Thickness (m)	WBZ Type	S.W.L. (m)	D.D.L. (m)	Yield (L/s)	Hole Depth (m)	Duration (hr)	Salinity (mg/L)
10.00	18.00	8.00	Unknown			0.12			
25.00	26.00	1.00	Unknown			0.48			

Drillers Log

From (m)	To (m)	Thickness (m)	Drillers Description	Geological Material	Comments
0.00	0.30	0.30	topsoil	Topsoil	
0.30	3.00	2.70	clay	Clay	
3.00	17.00	14.00	basalt	Basalt	

17.00	18.00	1.00	basalt/broken	Basalt	
18.00	25.00	7.00	basalt	Basalt	
25.00	26.00	1.00	basalt/broken	Basalt	
26.00	33.00	7.00	basalt	Basalt	

***** End of GW965621 *****

Warning To Clients: This raw data has been supplied to the NSW Office of Water by drillers, licensees and other sources. The NOW does not verify the accuracy of this data. The data is presented for use by you at your own risk. You should consider verifying this data before relying on it. Professional hydrogeological advice should be sought in interpreting and using this data.

APPENDIX D – PROTECTED MATTERS SEARCH TOOL (MNES)



EPBC Act Protected Matters Report

This report provides general guidance on matters of national environmental significance and other matters protected by the EPBC Act in the area you have selected.

Information on the coverage of this report and qualifications on data supporting this report are contained in the caveat at the end of the report.

Information is available about [Environment Assessments](#) and the EPBC Act including significance guidelines, forms and application process details.

Report created: 14/09/20 11:53:27

[Summary](#)

[Details](#)

[Matters of NES](#)

[Other Matters Protected by the EPBC Act](#)

[Extra Information](#)

[Caveat](#)

[Acknowledgements](#)

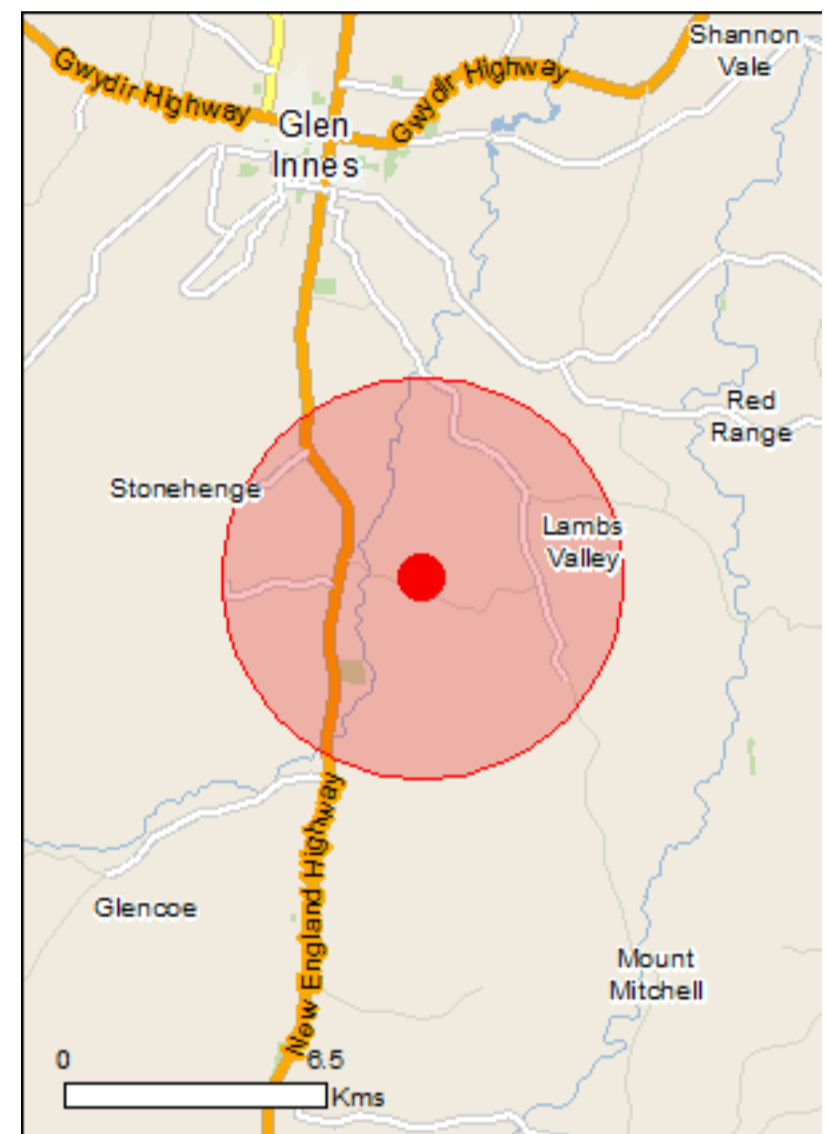

This map may contain data which are ©Commonwealth of Australia (Geoscience Australia), ©PSMA 2010

[Coordinates](#)

Buffer: 5.0Km

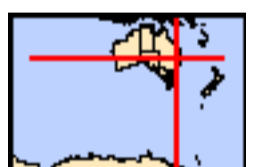

Summary

Matters of National Environmental Significance

This part of the report summarises the matters of national environmental significance that may occur in, or may relate to, the area you nominated. Further information is available in the detail part of the report, which can be accessed by scrolling or following the links below. If you are proposing to undertake an activity that may have a significant impact on one or more matters of national environmental significance then you should consider the [Administrative Guidelines on Significance](#).

World Heritage Properties:	None
National Heritage Places:	None
Wetlands of International Importance:	3
Great Barrier Reef Marine Park:	None
Commonwealth Marine Area:	None
Listed Threatened Ecological Communities:	4
Listed Threatened Species:	34
Listed Migratory Species:	11

Other Matters Protected by the EPBC Act

This part of the report summarises other matters protected under the Act that may relate to the area you nominated. Approval may be required for a proposed activity that significantly affects the environment on Commonwealth land, when the action is outside the Commonwealth land, or the environment anywhere when the action is taken on Commonwealth land. Approval may also be required for the Commonwealth or Commonwealth agencies proposing to take an action that is likely to have a significant impact on the environment anywhere.

The EPBC Act protects the environment on Commonwealth land, the environment from the actions taken on Commonwealth land, and the environment from actions taken by Commonwealth agencies. As heritage values of a place are part of the 'environment', these aspects of the EPBC Act protect the Commonwealth Heritage values of a Commonwealth Heritage place. Information on the new heritage laws can be found at <http://www.environment.gov.au/heritage>

A [permit](#) may be required for activities in or on a Commonwealth area that may affect a member of a listed threatened species or ecological community, a member of a listed migratory species, whales and other cetaceans, or a member of a listed marine species.

Commonwealth Land:	1
Commonwealth Heritage Places:	None
Listed Marine Species:	17
Whales and Other Cetaceans:	None
Critical Habitats:	None
Commonwealth Reserves Terrestrial:	None
Australian Marine Parks:	None

Extra Information

This part of the report provides information that may also be relevant to the area you have nominated.

State and Territory Reserves:	None
Regional Forest Agreements:	1
Invasive Species:	21
Nationally Important Wetlands:	None
Key Ecological Features (Marine)	None

Details

Matters of National Environmental Significance

Wetlands of International Importance (Ramsar)	[Resource Information]
Name	Proximity
Banrock station wetland complex	1100 - 1200km
Riverland	1100 - 1200km
The coorong, and lakes alexandrina and albert wetland	1300 - 1400km

Listed Threatened Ecological Communities [Resource Information]

For threatened ecological communities where the distribution is well known, maps are derived from recovery plans, State vegetation maps, remote sensing imagery and other sources. Where threatened ecological community distributions are less well known, existing vegetation maps and point location data are used to produce indicative distribution maps.

Name	Status	Type of Presence
Natural grasslands on basalt and fine-textured alluvial plains of northern New South Wales and southern Queensland	Critically Endangered	Community may occur within area
New England Peppermint (<i>Eucalyptus nova-anglica</i>) Grassy Woodlands	Critically Endangered	Community likely to occur within area
Upland Wetlands of the New England Tablelands (New England Tableland Bioregion) and the Monaro Plateau (South Eastern Highlands Bioregion)	Endangered	Community likely to occur within area
White Box-Yellow Box-Blakely's Red Gum Grassy Woodland and Derived Native Grassland	Critically Endangered	Community likely to occur within area

Listed Threatened Species [Resource Information]

Name	Status	Type of Presence
Birds		
Anthochaera phrygia Regent Honeyeater [82338]	Critically Endangered	Foraging, feeding or related behaviour may occur within area
Botaurus poiciloptilus Australasian Bittern [1001]	Endangered	Species or species habitat may occur within area
Calidris ferruginea Curlew Sandpiper [856]	Critically Endangered	Species or species habitat may occur within area
Erythrotriorchis radiatus Red Goshawk [942]	Vulnerable	Species or species habitat likely to occur within area
Falco hypoleucos Grey Falcon [929]	Vulnerable	Species or species habitat likely to occur within area
Geophaps scripta scripta Squatter Pigeon (southern) [64440]	Vulnerable	Species or species habitat may occur within area
Grantiella picta Painted Honeyeater [470]	Vulnerable	Species or species habitat likely to occur within area

Name	Status	Type of Presence
Hirundapus caudacutus White-throated Needletail [682]	Vulnerable	Species or species habitat likely to occur within area
Lathamus discolor Swift Parrot [744]	Critically Endangered	Species or species habitat may occur within area
Rostratula australis Australian Painted Snipe [77037]	Endangered	Species or species habitat likely to occur within area
Fish		
Maccullochella peelii Murray Cod [66633]	Vulnerable	Species or species habitat likely to occur within area
Frogs		
Litoria castanea Yellow-spotted Tree Frog, Yellow-spotted Bell Frog [1848]	Critically Endangered	Species or species habitat likely to occur within area
Mammals		
Chalinolobus dwyeri Large-eared Pied Bat, Large Pied Bat [183]	Vulnerable	Species or species habitat likely to occur within area
Dasyurus maculatus maculatus (SE mainland population) Spot-tailed Quoll, Spotted-tail Quoll, Tiger Quoll (southeastern mainland population) [75184]	Endangered	Species or species habitat known to occur within area
Nyctophilus corbeni Corben's Long-eared Bat, South-eastern Long-eared Bat [83395]	Vulnerable	Species or species habitat may occur within area
Petauroides volans Greater Glider [254]	Vulnerable	Species or species habitat likely to occur within area
Petrogale penicillata Brush-tailed Rock-wallaby [225]	Vulnerable	Species or species habitat may occur within area
Phascolarctos cinereus (combined populations of Qld, NSW and the ACT) Koala (combined populations of Queensland, New South Wales and the Australian Capital Territory) [85104]	Vulnerable	Species or species habitat likely to occur within area
Potorous tridactylus tridactylus Long-nosed Potoroo (SE Mainland) [66645]	Vulnerable	Species or species habitat may occur within area
Pteropus poliocephalus Grey-headed Flying-fox [186]	Vulnerable	Foraging, feeding or related behaviour may occur within area
Plants		
Arthraxon hispidus Hairy-joint Grass [9338]	Vulnerable	Species or species habitat likely to occur within area
Boronia granitica Granite Boronia [18598]	Endangered	Species or species habitat may occur within area
Callistemon pungens [55581]	Vulnerable	Species or species habitat likely to occur within area
Cryptostylis hunteriana Leafless Tongue-orchid [19533]	Vulnerable	Species or species habitat may occur within area

Name	Status	Type of Presence
Dichanthium setosum bluegrass [14159]	Vulnerable	Species or species habitat likely to occur within area
Diuris pedunculata Small Snake Orchid, Two-leaved Golden Moths, Golden Moths, Cowslip Orchid, Snake Orchid [18325]	Endangered	Species or species habitat likely to occur within area
Eucalyptus mckieana McKie's Stringybark [20199]	Vulnerable	Species or species habitat may occur within area
Eucalyptus nicholii Narrow-leaved Peppermint, Narrow-leaved Black Peppermint [20992]	Vulnerable	Species or species habitat likely to occur within area
Haloragis exalata subsp. velutina Tall Velvet Sea-berry [16839]	Vulnerable	Species or species habitat may occur within area
Prasophyllum sp. Wybong (C.Phelps ORG 5269) a leek-orchid [81964]	Critically Endangered	Species or species habitat may occur within area
Thesium australe Austral Toadflax, Toadflax [15202]	Vulnerable	Species or species habitat likely to occur within area
Tylophora woollsii [20503]	Endangered	Species or species habitat may occur within area
Reptiles		
Uvidicolus sphyrurus Border Thick-tailed Gecko, Granite Belt Thick-tailed Gecko [84578]	Vulnerable	Species or species habitat may occur within area
Wollumbinia belli Bell's Turtle, Western Sawshelled Turtle, Namoi River Turtle, Bell's Saw-shelled Turtle [86071]	Vulnerable	Species or species habitat likely to occur within area
Listed Migratory Species		[Resource Information]
* Species is listed under a different scientific name on the EPBC Act - Threatened Species list.		
Name	Threatened	Type of Presence
Migratory Marine Birds		
Apus pacificus Fork-tailed Swift [678]		Species or species habitat likely to occur within area
Migratory Terrestrial Species		
Hirundapus caudacutus White-throated Needletail [682]	Vulnerable	Species or species habitat likely to occur within area
Monarcha melanopsis Black-faced Monarch [609]		Species or species habitat likely to occur within area
Motacilla flava Yellow Wagtail [644]		Species or species habitat may occur within area
Myiagra cyanoleuca Satin Flycatcher [612]		Species or species habitat likely to occur within area
Rhipidura rufifrons Rufous Fantail [592]		Species or species habitat likely to occur within area
Migratory Wetlands Species		

Name	Threatened	Type of Presence
Actitis hypoleucos Common Sandpiper [59309]		Species or species habitat may occur within area
Calidris acuminata Sharp-tailed Sandpiper [874]		Species or species habitat may occur within area
Calidris ferruginea Curlew Sandpiper [856]	Critically Endangered	Species or species habitat may occur within area
Calidris melanotos Pectoral Sandpiper [858]		Species or species habitat may occur within area
Gallinago hardwickii Latham's Snipe, Japanese Snipe [863]		Species or species habitat may occur within area

Other Matters Protected by the EPBC Act

Commonwealth Land [\[Resource Information \]](#)

The Commonwealth area listed below may indicate the presence of Commonwealth land in this vicinity. Due to the unreliability of the data source, all proposals should be checked as to whether it impacts on a Commonwealth area, before making a definitive decision. Contact the State or Territory government land department for further information.

Name
Commonwealth Land - Australian Telecommunications Commission

Listed Marine Species [\[Resource Information \]](#)

* Species is listed under a different scientific name on the EPBC Act - Threatened Species list.

Name	Threatened	Type of Presence
Birds		
Actitis hypoleucos Common Sandpiper [59309]		Species or species habitat may occur within area
Apus pacificus Fork-tailed Swift [678]		Species or species habitat likely to occur within area
Ardea alba Great Egret, White Egret [59541]		Species or species habitat likely to occur within area
Ardea ibis Cattle Egret [59542]		Species or species habitat may occur within area
Calidris acuminata Sharp-tailed Sandpiper [874]		Species or species habitat may occur within area
Calidris ferruginea Curlew Sandpiper [856]	Critically Endangered	Species or species habitat may occur within area
Calidris melanotos Pectoral Sandpiper [858]		Species or species habitat may occur within area
Gallinago hardwickii Latham's Snipe, Japanese Snipe [863]		Species or species habitat may occur within area
Haliaeetus leucogaster White-bellied Sea-Eagle [943]		Species or species

Name	Threatened	Type of Presence
Hirundapus caudacutus White-throated Needletail [682]	Vulnerable	habitat known to occur within area Species or species habitat likely to occur within area
Lathamus discolor Swift Parrot [744]	Critically Endangered	Species or species habitat may occur within area
Merops ornatus Rainbow Bee-eater [670]		Species or species habitat may occur within area
Monarcha melanopsis Black-faced Monarch [609]		Species or species habitat likely to occur within area
Motacilla flava Yellow Wagtail [644]		Species or species habitat may occur within area
Myiagra cyanoleuca Satin Flycatcher [612]		Species or species habitat likely to occur within area
Rhipidura rufifrons Rufous Fantail [592]		Species or species habitat likely to occur within area
Rostratula benghalensis (sensu lato) Painted Snipe [889]	Endangered*	Species or species habitat likely to occur within area

Extra Information

Regional Forest Agreements [\[Resource Information \]](#)

Note that all areas with completed RFAs have been included.

Name	State
North East NSW RFA	New South Wales

Invasive Species [\[Resource Information \]](#)

Weeds reported here are the 20 species of national significance (WoNS), along with other introduced plants that are considered by the States and Territories to pose a particularly significant threat to biodiversity. The following feral animals are reported: Goat, Red Fox, Cat, Rabbit, Pig, Water Buffalo and Cane Toad. Maps from Landscape Health Project, National Land and Water Resources Audit, 2001.

Name	Status	Type of Presence
Birds		
Carduelis carduelis European Goldfinch [403]		Species or species habitat likely to occur within area
Columba livia Rock Pigeon, Rock Dove, Domestic Pigeon [803]		Species or species habitat likely to occur within area
Passer domesticus House Sparrow [405]		Species or species habitat likely to occur within area
Sturnus vulgaris Common Starling [389]		Species or species habitat likely to occur within area
Turdus merula Common Blackbird, Eurasian Blackbird [596]		Species or species habitat likely to occur

Name	Status	Type of Presence within area
Frogs		
Rhinella marina Cane Toad [83218]		Species or species habitat may occur within area
Mammals		
Canis lupus familiaris Domestic Dog [82654]		Species or species habitat likely to occur within area
Capra hircus Goat [2]		Species or species habitat likely to occur within area
Felis catus Cat, House Cat, Domestic Cat [19]		Species or species habitat likely to occur within area
Lepus capensis Brown Hare [127]		Species or species habitat likely to occur within area
Mus musculus House Mouse [120]		Species or species habitat likely to occur within area
Oryctolagus cuniculus Rabbit, European Rabbit [128]		Species or species habitat likely to occur within area
Rattus rattus Black Rat, Ship Rat [84]		Species or species habitat likely to occur within area
Sus scrofa Pig [6]		Species or species habitat likely to occur within area
Vulpes vulpes Red Fox, Fox [18]		Species or species habitat likely to occur within area
Plants		
Cytisus scoparius Broom, English Broom, Scotch Broom, Common Broom, Scottish Broom, Spanish Broom [5934]		Species or species habitat likely to occur within area
Genista sp. X Genista monspessulana Broom [67538]		Species or species habitat may occur within area
Nassella neesiana Chilean Needle grass [67699]		Species or species habitat likely to occur within area
Nassella trichotoma Serrated Tussock, Yass River Tussock, Yass Tussock, Nassella Tussock (NZ) [18884]		Species or species habitat likely to occur within area
Pinus radiata Radiata Pine Monterey Pine, Insignis Pine, Wilding Pine [20780]		Species or species habitat may occur within area
Rubus fruticosus aggregate Blackberry, European Blackberry [68406]		Species or species habitat likely to occur within area

Caveat

The information presented in this report has been provided by a range of data sources as acknowledged at the end of the report.

This report is designed to assist in identifying the locations of places which may be relevant in determining obligations under the Environment Protection and Biodiversity Conservation Act 1999. It holds mapped locations of World and National Heritage properties, Wetlands of International and National Importance, Commonwealth and State/Territory reserves, listed threatened, migratory and marine species and listed threatened ecological communities. Mapping of Commonwealth land is not complete at this stage. Maps have been collated from a range of sources at various resolutions.

Not all species listed under the EPBC Act have been mapped (see below) and therefore a report is a general guide only. Where available data supports mapping, the type of presence that can be determined from the data is indicated in general terms. People using this information in making a referral may need to consider the qualifications below and may need to seek and consider other information sources.

For threatened ecological communities where the distribution is well known, maps are derived from recovery plans, State vegetation maps, remote sensing imagery and other sources. Where threatened ecological community distributions are less well known, existing vegetation maps and point location data are used to produce indicative distribution maps.

Threatened, migratory and marine species distributions have been derived through a variety of methods. Where distributions are well known and if time permits, maps are derived using either thematic spatial data (i.e. vegetation, soils, geology, elevation, aspect, terrain, etc) together with point locations and described habitat; or environmental modelling (MAXENT or BIOCLIM habitat modelling) using point locations and environmental data layers.

Where very little information is available for species or large number of maps are required in a short time-frame, maps are derived either from 0.04 or 0.02 decimal degree cells; by an automated process using polygon capture techniques (static two kilometre grid cells, alpha-hull and convex hull); or captured manually or by using topographic features (national park boundaries, islands, etc). In the early stages of the distribution mapping process (1999-early 2000s) distributions were defined by degree blocks, 100K or 250K map sheets to rapidly create distribution maps. More reliable distribution mapping methods are used to update these distributions as time permits.

Only selected species covered by the following provisions of the EPBC Act have been mapped:

- migratory and
- marine

The following species and ecological communities have not been mapped and do not appear in reports produced from this database:

- threatened species listed as extinct or considered as vagrants
- some species and ecological communities that have only recently been listed
- some terrestrial species that overfly the Commonwealth marine area
- migratory species that are very widespread, vagrant, or only occur in small numbers

The following groups have been mapped, but may not cover the complete distribution of the species:

- non-threatened seabirds which have only been mapped for recorded breeding sites
- seals which have only been mapped for breeding sites near the Australian continent

Such breeding sites may be important for the protection of the Commonwealth Marine environment.

Coordinates

-29.82283 151.75875

Acknowledgements

This database has been compiled from a range of data sources. The department acknowledges the following custodians who have contributed valuable data and advice:

- [-Office of Environment and Heritage, New South Wales](#)
- [-Department of Environment and Primary Industries, Victoria](#)
- [-Department of Primary Industries, Parks, Water and Environment, Tasmania](#)
- [-Department of Environment, Water and Natural Resources, South Australia](#)
- [-Department of Land and Resource Management, Northern Territory](#)
- [-Department of Environmental and Heritage Protection, Queensland](#)
- [-Department of Parks and Wildlife, Western Australia](#)
- [-Environment and Planning Directorate, ACT](#)
- [-Birdlife Australia](#)
- [-Australian Bird and Bat Banding Scheme](#)
- [-Australian National Wildlife Collection](#)
- [-Natural history museums of Australia](#)
- [-Museum Victoria](#)
- [-Australian Museum](#)
- [-South Australian Museum](#)
- [-Queensland Museum](#)
- [-Online Zoological Collections of Australian Museums](#)
- [-Queensland Herbarium](#)
- [-National Herbarium of NSW](#)
- [-Royal Botanic Gardens and National Herbarium of Victoria](#)
- [-Tasmanian Herbarium](#)
- [-State Herbarium of South Australia](#)
- [-Northern Territory Herbarium](#)
- [-Western Australian Herbarium](#)
- [-Australian National Herbarium, Canberra](#)
- [-University of New England](#)
- [-Ocean Biogeographic Information System](#)
- [-Australian Government, Department of Defence Forestry Corporation, NSW](#)
- [-Geoscience Australia](#)
- [-CSIRO](#)
- [-Australian Tropical Herbarium, Cairns](#)
- [-eBird Australia](#)
- [-Australian Government – Australian Antarctic Data Centre](#)
- [-Museum and Art Gallery of the Northern Territory](#)
- [-Australian Government National Environmental Science Program](#)
- [-Australian Institute of Marine Science](#)
- [-Reef Life Survey Australia](#)
- [-American Museum of Natural History](#)
- [-Queen Victoria Museum and Art Gallery, Inveresk, Tasmania](#)
- [-Tasmanian Museum and Art Gallery, Hobart, Tasmania](#)
- [-Other groups and individuals](#)

The Department is extremely grateful to the many organisations and individuals who provided expert advice and information on numerous draft distributions.

Please feel free to provide feedback via the [Contact Us](#) page.

APPENDIX E – AHIMS SEARCH

AgDSA
21 Kennard Street
Westbrook Queensland 4350
Attention: Matt Norton

Date: 14 September 2020

Email: matt.norton@agdsa.com.au

Dear Sir or Madam:

AHIMS Web Service search for the following area at Lot : 1, DP:DP7243 with a Buffer of 1000 meters, conducted by Matt Norton on 14 September 2020.

The context area of your search is shown in the map below. Please note that the map does not accurately display the exact boundaries of the search as defined in the paragraph above. The map is to be used for general reference purposes only.

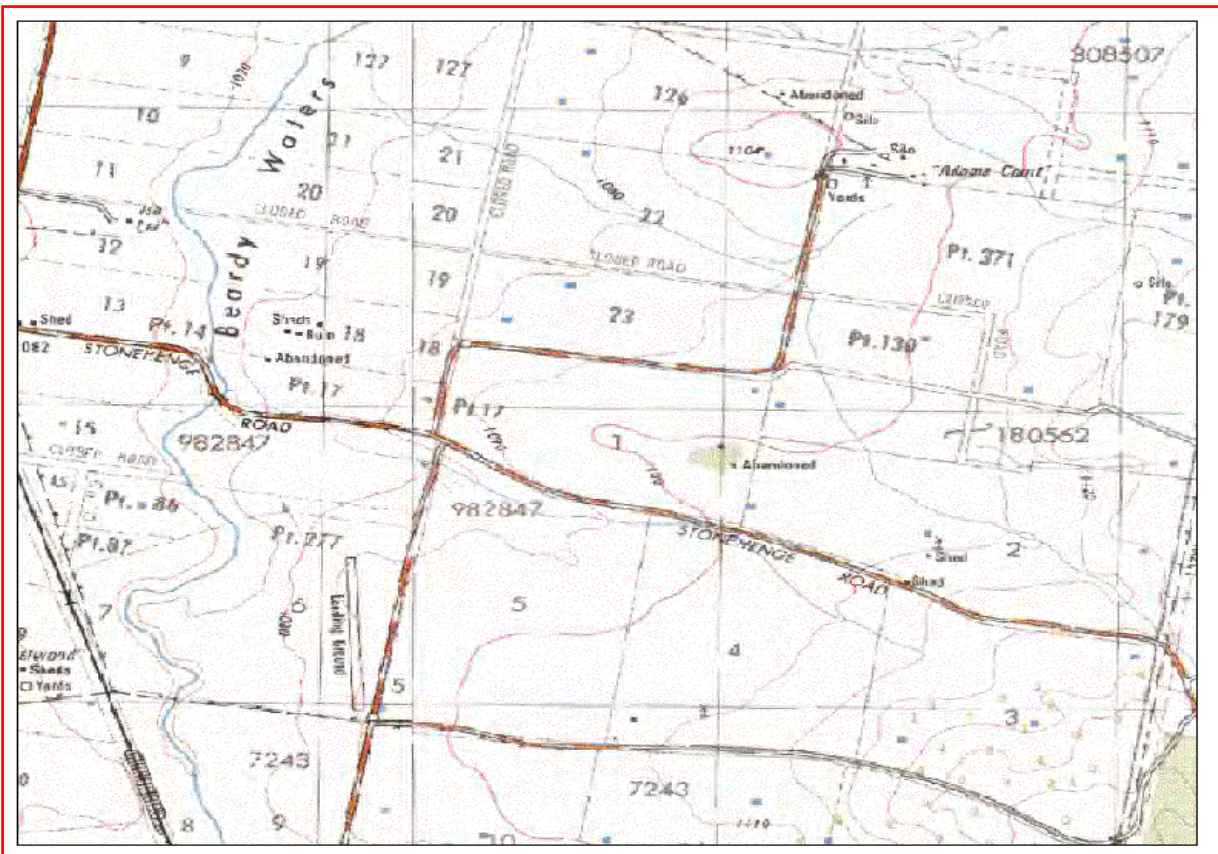

A search of the Office of the Environment and Heritage AHIMS Web Services (Aboriginal Heritage Information Management System) has shown that:

0	Aboriginal sites are recorded in or near the above location.
0	Aboriginal places have been declared in or near the above location. *

If your search shows Aboriginal sites or places what should you do?

- You must do an extensive search if AHIMS has shown that there are Aboriginal sites or places recorded in the search area.
- If you are checking AHIMS as a part of your due diligence, refer to the next steps of the Due Diligence Code of practice.
- You can get further information about Aboriginal places by looking at the gazettal notice that declared it. Aboriginal places gazetted after 2001 are available on the [NSW Government Gazette \(http://www.nsw.gov.au/gazette\)](http://www.nsw.gov.au/gazette) website. Gazettal notices published prior to 2001 can be obtained from Office of Environment and Heritage's Aboriginal Heritage Information Unit upon request

Important information about your AHIMS search

- The information derived from the AHIMS search is only to be used for the purpose for which it was requested. It is not be made available to the public.
- AHIMS records information about Aboriginal sites that have been provided to Office of Environment and Heritage and Aboriginal places that have been declared by the Minister;
- Information recorded on AHIMS may vary in its accuracy and may not be up to date .Location details are recorded as grid references and it is important to note that there may be errors or omissions in these recordings,
- Some parts of New South Wales have not been investigated in detail and there may be fewer records of Aboriginal sites in those areas. These areas may contain Aboriginal sites which are not recorded on AHIMS.
- Aboriginal objects are protected under the National Parks and Wildlife Act 1974 even if they are not recorded as a site on AHIMS.
- This search can form part of your due diligence and remains valid for 12 months.

APPENDIX F – LIVESTOCK THROUGHPUT SPREADSHEET

The AgDSA Beef Feedlot Feed, Manure & Traffic Calculator has been developed to assist the preparation of development applications for beef feedlots in Australia.

Cattle stocking rates used to estimate cattle capacities per truck are based on the 2019 Meat & Livestock Australia (MLA) "Fit to Load" manual. Cattle weight above of below those provided in the manual have been interpolated or extrapolated as required.

Legend

 Data is to be entered into all of the grey cells, starting with the '1 - General' worksheet and proceeding through the other worksheets from left to right, using the tabs on the bottom of the screen.

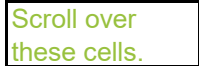
 For assistance with the selection of appropriate input data, scroll over the cells that have red triangles in the upper right corner to view explanatory comments.

Developed by: Tim Sullivan
Principal Agricultural Engineer
AgDSA
Email: tim.sullivan@agdsa.com.au



General Feedlot Information

Feedlot Details

Feedlot Development

Landholders' name(s):	Jardana	Is the feedlot developed in stages	No						
Cattle feedlot name:									
Feedlot address:	Pedlows Road	Cattle capacity per stage (SCU)	Stage 1	Stage 2	Stage 3	Stage 4	Stage 5	Total	
Feedlot locality:		Pen numbers (as per plan)	1,000					1,000	
Feedlot State:	NSW	Anticipated completion date							
Feedlot Local Government Area:	Glen Innes								
Spreadsheet user name	MRN								
Assessment date									



Cattle Movements

Expansion Stage	1	2	3	4	5	Total	Units
Maximum SCU Capacity	1,000	-	-	-	-	1,000	SCU
Animal Performance Data							
Entry Weight	380						kg
Exit Weight	520						kg
Average Weight	450	-	-	-	-		kg
SCU Conversion (at average weight)	0.81	-	-	-	-		
SCU Conversion (at turnoff weight)	0.90	-	-	-	-		
Total Days on Feed	100						Days
Feed cycles per year	3.65	-	-	-	-		
Average Occupancy Rate	80%						80% %
Average SCU in Feedlot	800	-	-	-	-	800	SCU
Average Head in Feedlot	993	-	-	-	-	993	Head
Maximum Head in Feedlot (100% Occupancy)	1,241	-	-	-	-	1,241	Head
Total Cattle Entering the Feedlot	3,623	-	-	-	-	3,623	Head
Average Mortality	1.00%						1.00% %
Annual Deaths	36	-	-	-	-	36	Head
Outgoing Cattle	3,587	-	-	-	-	3,587	Head
Cattle Procurement							
Cattle Produced Onsite	1,780						Head
Cattle Produced Per Stage	1,780	0	0	0	0	1,780	Head
Cattle Produced Onsite	49.1%					49.1%	%
Cattle Transported In	1,843	-	-	-	-	1,843	Head
Cattle Transported In	50.9%					50.9%	%
Incoming Cattle Trucks							
Incoming Cattle	1,843	-	-	-	-		
Incoming Cattle Truck Type	B Double						Type
Total Decks / Truck Type	3	-	-	-	-		kg
Incoming Cattle Weight	380	-	-	-	-		kg
Incoming Cattle Floor Area	1.02	-	-	-	-		m ² /head
Incoming Cattle/Deck	28	-	-	-	-		Head
Outgoing Cattle/Truck (Space Limiting)	84	-	-	-	-		Head
Outgoing Cattle/Truck	80						Head
Incoming Cattle Trucks/year	23	-	-	-	-	23	Trucks/year
Outgoing Cattle Trucks							
Outgoing Cattle	3,587	-	-	-	-		
Outgoing Cattle Truck Type	B Double						Type
Total Decks / Truck Type	3	-	-	-	-		kg
Outgoing Cattle Weight	520	-	-	-	-		kg
Outgoing Cattle Floor Area	1.27	#N/A	#N/A	#N/A	#N/A		m ² /head
Outgoing Cattle/Deck	23	#N/A	#N/A	#N/A	#N/A		Head
Outgoing Cattle/Truck (Space Limiting)	69	#N/A	#N/A	#N/A	#N/A		Head
Outgoing Cattle/Truck	60						Head
Outgoing Cattle Trucks/Year	60	-	-	-	-	60	Trucks/year



Feedstuff Requirements

Expansion Stage	1	2	3	4	5	Total	Units
Maximum SCU Capacity	1,000	-	-	-	-	1,000	SCU
Animal Performance Data							
Entry Weight	380	0	-	-	-	-	kg
Exit Weight	520	0	-	-	-	-	kg
Average Weight	450	0	-	-	-	-	kg
SCU Conversion (at average weight)	0.81	-	-	-	-	-	
Average Occupancy Rate			80%				80% %
Average SCU in Feedlot	800						800 SCU
Average Head in Feedlot	993						993 Head
Maximum Head Capacity	1,241						1,241 Head
Animal Feed Intake							
As fed intake	2.7%	0.0%	0.0%	0.0%	0.0%		% Avg. LWT
As fed intake	12.0						kg/day
Ration Dry Matter	80%						%
DM feed intake	9.6						kg/day
Days on Feed	100.0						days
Daily Gain	1.4						kg/day
FCR (as fed basis)	8.6						x:1
FCR (DM basis)	6.9	#DIV/0!	#DIV/0!	#DIV/0!	#DIV/0!		x:1
Feed consumed onsite/day	11.9						11.9 t/day
Feed consumed onsite/week	83.4						83.4 t/week
Feed consumed onsite/year	4,347.8						4,347.8 t/year
Diet & Ingredient Volumes							
Grain	75.0%						%
Roughage (Hay/Straw)							%
Roughage (Silage)	16.0%						%
Liquids + Supplements	9.0%						%
Total	100.0%	0.0%	0.0%	0.0%	0.0%		%
Annual Feed Requirements							
Grain	3,260.8						3,260.8 t/year
Roughage (Hay/Straw)	-						- t/year
Roughage (Silage)	695.6						695.6 t/year
Liquids + Supplements	391.3						391.3 t/year
Total	4,347.8						4,347.8 t/year
	OK	OK	OK	OK	OK	OK	
Annual Feed Grown Onsite							
Grains produced onsite			900				900 t/year
	900						t/stage/year
	27.6%						27.6% % supplied from onsite
Roughage (Hay/Straw) produced onsite							- t/year
							t/stage/year
							% supplied from onsite
Roughage (Silage) produced onsite			3,500				696 t/year
	696						t/stage/year
	100.0%						100.0% % supplied from onsite
Liquid + Supplements produced onsite							- t/year
							t/stage/year
							% supplied from onsite
Total feed produced onsite	1,596						1,596 t/year
	36.7%						36.7% % supplied from onsite
Commodity Truck Movements							
Grain - Ex. Farm Grown	2,361						2,361 t/year
Grain Truck Type	B Double						Type
Grain Truck Capacity (Suggested)	36						t/vehicle
Grain Truck Capacity (Used)	36						t/vehicle
Grain Truck Loads	66						66 Trucks/yr
Roughage (Hay/Straw) - Ex. Farm Grown							- t/year
Roughage (Hay/Straw) Truck Type	B Double						Type
Roughage (Hay/Straw) Truck Capacity (Suggested)	18						t/vehicle
Roughage (Hay/Straw) Truck Capacity (Used)	18						t/vehicle
Roughage (Hay/Straw) Truck Loads							- Trucks/yr
Roughage (Silage) - Ex. Farm Grown							- t/year
Roughage (Silage) Truck Type	B Double						Type
Roughage (Silage) Truck Capacity (Suggested)	36						t/vehicle
Roughage (Silage) Truck Capacity (Used)	36						t/vehicle
Roughage (Silage) Truck Loads							- Trucks/yr
Liquids + Supplements - Ex. Farm Grown	391						391 t/year
Liquids + Supplements Truck Type	B Double						Type
Liquids + Supplements Truck Capacity (Suggested)	36						t/vehicle
Liquids + Supplements Truck Capacity (Used)	36						t/vehicle
Liquids + Supplements Truck Loads	11						11 Trucks/yr



Manure Production Details

Expansion Stage	1	2	3	4	5	Total	Units
Maximum SCU Capacity	1,000	-	-	-	-	-	1,000 SCU
Occupancy Rate			80%				80% %
Average SCU in Feedlot	800	-	-	-	-	-	800 SCU
Manure Production							
Average raw manure harvested per SCU	0.80	0.80	0.80	0.80	0.80	0.80	0.80 t/SCU/yr
Average annual raw manure harvested	640	-	-	-	-	-	640 t/year
Manure processing utilised	Stockpiled	Stockpiled	Stockpiled	Stockpiled	Stockpiled	Stockpiled	
Average raw/processed manure per scu	0.56	0.56	0.56	0.56	0.56	0.56	t/SCU/yr
Average annual manure for reuse	448	0	0	0	0	0	448
Manure exported off-site annually	0.0	0.0	0.0	0.0	0.0	0.0	0 t/yr
Manure exported off-site annually	0%	#DIV/0!	#DIV/0!	#DIV/0!	#DIV/0!	#DIV/0!	0% %
Manure transport typical truck type	Semi Trailer	Semi Trailer	Semi Trailer	Semi Trailer	Semi Trailer	Semi Trailer	
Tonnes of manure/truckload	24	24	24	24	24	24	t/vehicle
No. outgoing trucks/year	0.0	0.0	0.0	0.0	0.0	0.0	0.0 truck/yr



Traffic Generation - Individual Stages

Expansion Stage	1	2	3	4	5	Total	Units
Incoming Cattle (Excludes farm grown)							
Average Occupancy	80%	0%	0%	0%	0%	%	
Cattle per year	1,843	-	-	-	-	1,843	head/year
Typical truck type	B Double	-	-	-	-	-	
No. of head/truck	80	-	-	-	-		head/truck
No. of trucks/year	23	-	-	-	-	23	trucks/year
No. of trucks/week	0.4	-	-	-	-	0.4	trucks/week
No. of trucks/day	0.1	-	-	-	-	0.1	trucks/day
Outgoing Cattle							
Cattle out per year	3,587	-	-	-	-	3,587	head/year
Typical truck type	B Double	-	-	-	-	-	
No. of Head/truck	60	-	-	-	-		head/truck
No. of trucks/year	60	-	-	-	-	60	trucks/year
No. of trucks/week	1.1	-	-	-	-	1.1	trucks/week
No. of trucks/day	0.2	-	-	-	-	0.2	trucks/day
Grain and Feedstuffs							
Total feed Imported Ex. Farm Grown	2,752	-	-	-	-	2,752	t/year
Typical truck type	B Double	-	-	-	-	-	
No. of trucks/year	76	-	-	-	-	76	trucks/year
No. of trucks/week	1.5	-	-	-	-	1.5	trucks/week
No. of trucks/day	0.2	-	-	-	-	0.2	trucks/day
Outgoing Manure							
Manure transported off-site	0	0	0	0	0	0	t/year
Typical truck type	Semi Trailer	Semi Trailer	Semi Trailer	Semi Trailer	Semi Trailer		
No. of trucks/year	0	0	0	0	0	0	trucks/year
No. of trucks/week	0.0	0.0	0.0	0.0	0.0	0.0	trucks/week
No. of trucks/day	0.0	0.0	0.0	0.0	0.0	0.0	trucks/day
Total - Incoming and Outgoing Trucks							
No. of trucks - Incoming Cattle & Incoming Feed Commodities	99	-	-	-	-	99	trucks/year
Incoming Annual Average Daily Traffic (AADT)	0.3	-	-	-	-	0.3	trucks/day
No. of trucks - Outgoing Cattle & Manure taken for offsite disposal	0.5	-	-	-	-	0.5	trucks/day
Outgoing Annual Average Daily Traffic (AADT)	0.2	0.0	0.0	0.0	0.0	0.2	trucks/day
Total - Incoming & Outgoing Trucks	159	0	0	0	0	159	trucks/year
	3	0	0	0	0	3	trucks/week

Traffic Generation - Cumulative Stages

Expansion Stage	1	1+2	1+2+3	1+2+3+4	1+2+3+4+5	Units
Incoming Cattle (Excludes farm grown)						
Average Occupancy	80%	0%	0%	0%	0%	%
Cattle per year	1,843	-	-	-	-	head/year
Typical truck type	B Double	-	-	-	-	
No. of head/truck	80	-	-	-	-	head/truck
No. of trucks/year	23	-	-	-	-	trucks/year
No. of trucks/week	0.4	-	-	-	-	trucks/week
No. of trucks/day	0.1	-	-	-	-	trucks/day
Outgoing Cattle						
Cattle out per year	3,587	-	-	-	-	head/year
Typical truck type	B Double	-	-	-	-	
No. of Head/truck	60	-	-	-	-	head/truck
No. of trucks/year	60	-	-	-	-	trucks/year
No. of trucks/week	1.1	-	-	-	-	trucks/week
No. of trucks/day	0.2	-	-	-	-	trucks/day
Grain and Feedstuffs						
Total feed Imported Ex. Farm Grown	2,752	-	-	-	-	t/year
Typical truck type	B Double	-	-	-	-	
No. of trucks/year	76	-	-	-	-	trucks/year
No. of trucks/week	1.5	-	-	-	-	trucks/week
No. of trucks/day	0.2	-	-	-	-	trucks/day
Outgoing Manure						
Manure transported off-site	0	0	0	0	0	t/year
Typical truck type	Semi Trailer	Semi Trailer	Semi Trailer	Semi Trailer	Semi Trailer	
No. of trucks/year	0	0	0	0	0	trucks/year
No. of trucks/week	0.0	0.0	0.0	0.0	0.0	trucks/week
No. of trucks/day	0.0	0.0	0.0	0.0	0.0	trucks/day
Total - Incoming and Outgoing Trucks						
No. of trucks - Incoming Cattle & Incoming Feed Commodities	99	-	-	-	-	trucks/year
Incoming Annual Average Daily Traffic (AADT)	0.3	-	-	-	-	trucks/day
No. of trucks - Outgoing Cattle & Manure taken for offsite disposal	0.5	-	-	-	-	trucks/day
Outgoing Annual Average Daily Traffic (AADT)	0.2	0.2	0.2	0.2	0.2	trucks/day
Total - Incoming & Outgoing Trucks	159	159	159	159	159	trucks/year
	3	3	3	3	3	trucks/week



Average Annual Daily Traffic (AADT) Vehicle Comparison

Project Background Traffic

Design Horizon	Growth Year	AADT	Heavy Vehicles/Day	Light Vehicles/Day
2018	0	480	120	360
2019	1	498	125	374
2020	2	517	129	388
2021	3	536	134	402
2022	4	556	139	417
2023	5	577	144	433
2024	6	598	150	449
2025	7	620	155	465
2026	8	643	161	482
2027	9	667	167	500
2028	10	692	173	519
2029	11	717	179	538
2030	12	744	186	558
2031	13	772	193	579
2032	14	800	200	600
2033	15	830	208	623
2034	16	861	215	646
2035	17	893	223	670
2036	18	926	232	695
2037	19	960	240	720
2038	20	996	249	747

Historical Road Census Data

Traffic Census Year	AADT	Growth Rate
2014	400	
2015	414	3.50%
2016	430	3.86%
2017	450	4.65%
2018	465	3.33%
2019	480	3.23%
5		3.72%

Census Traffic Assumptions

Traffic Growth Rate	% Heavy Vehicle
3.72%	25%

Staff Travel Assumptions

Stage	Offsite Staff	Offsite Daily Vehicles	Offsite AADT (Light)
Stage 1	5	2	4
Stage 1+2	7	3	6
Stage 1+2+3	10	4	8
Stage 1+2+3+4	12	5	10
Stage 1+2+3+4+5	15	7	14

Proposed Traffic Impacts

Parameter	Stage 1	Stage 2	Stage 3	Stage 4	Stage 5
Anticipated Development Year	2020	2022	2024	2025	2030
Background Light Traffic	388	417	449	465	558
Feedlot AADT Light Traffic	4	6	8	10	14
Total AADT Light Post Construction	392	423	457	475	572
Increase in Light Traffic	1.03%	1.44%	1.78%	2.15%	2.51%
Background Heavy Traffic	129.3	139.0	149.5	155.0	186.0
Feedlot AADT Heavy Traffic	0	5	10	15	20
Total AADT Heavy Post Construction	129.3	144.0	159.5	170.0	206.0
Increase in Heavy Traffic	0.00%	3.60%	6.69%	9.68%	10.75%
Background Total Traffic	517.0	556.0	598.0	620.0	744.0
Feedlot AADT Total Traffic	4	11	18	25	34
Total AADT Total Post Construction	521.0	567.0	616.0	645.0	778.0
Increase in Total Traffic	0.77%	1.98%	3.01%	4.03%	4.57%

Table 1. Incoming cattle truck floor areas

Truck Type	Table Top	Semi Trailer (Single Deck)	Semi Trailer (Double Deck)	B Double	Road Train
Configuration	1 Deck	1 Deck	2 Decks	3 Decks	4 Decks
Total 12.5 x 2.4m decks	0.17	1	2	3	4
Total Floor Area (m ²)	5	29.3	58.5	87.8	117

Table 2. Minimum floor area by animal size

Mean liveweight (kg)	Area required (m ² /head)	Using Regression	% Difference	Head / Standard Deck
250	0.77	0.79	2.7%	38
300	0.86	0.86	0.6%	34
350	0.98	0.95	-3.4%	30
400	1.05	1.04	-1.4%	28
450	1.13	1.13	0.3%	26
500	1.23	1.24	0.8%	24
550	1.34	1.36	1.2%	22
600	1.47	1.48	1.0%	20
650	1.63	1.62	-0.4%	18
700	1.78	1.78		16
750	1.94	1.94		15
800	2.13	2.13		13
850	2.33	2.33		12
900	2.55	2.55		11
950	2.79	2.79		10
1000	3.05	3.05		9

Table 3. Incoming Grain truck loading rates

Commodity	Body Truck	Truck & Dog	Semi Trailer	B Double	Road Train
Grain (tonnes)	12	24	24	36	48

Table 4. Incoming Roughage - Hay/Straw truck loading rates

Commodity	Body Truck	Truck & Dog	Semi Trailer	B Double	Road Train
Roughage - Hay/Straw (tonnes)	6	12	12	18	24

Table 5. Incoming Roughage - Silage truck loading rates

Commodity	Body Truck	Truck & Dog	Semi Trailer	B Double	Road Train
Roughage - Silage (tonnes)	12	25	25	36	50

Table 6. Incoming Other - Liquids truck loading rates

Commodity	Body Truck	Truck & Dog	Semi Trailer	B Double	Road Train
Other - Liquids (tonnes)	12	24	24	36	48

Table 7. Manure quantities depending on manure treatment process

Truck Type	Tonne/SCU
Immediate Disposal	0.8
Stockpiled	0.56
Composted	0.35

Table 8. Outgoing manure truck loading rates

Truck Type	Tonne / truck
Body Truck	12
Truck & Dog	18
Semi Trailer	24
B double	36

APPENDIX G – WATER QUALITY ASSESSMENT

From: [Graham Lancaster](#)
To: [O Pedlow](#)
Subject: i3093.... Re: Re water sample summary for Jardana Feedlot
Date: Tuesday, 3 September 2019 6:52:54 AM
Attachments: [image001.jpg](#)

Kaylene,

In regard to your water quality see below for summary- sorry for the extreme delay getting onto this.

DAM WATER

The water quality of the Dam above the Feedlot (sample 1 of job i3094) is considered of good water quality characterised by

- Moderately alkaline pH
- Low salinity (ie. total dissolved salts) typical of dam waters influenced by ground water
- Moderately elevated suspended solids hence clarity not particularly good with likely fine clay particulates
- Fairly low water hardness and alkalinity
- Very low phosphorus
- Slightly elevated total nitrogen from the suspended matter but low nitrogen species
- Low breakdown of salts dominated by calcium and very low SAR
- Very low chloride and sulfate
- Slightly elevated bacteria as indicated by the Faecal coliforms
- Low metals dominated by iron, aluminium and manganese all likely related to the clay in the suspended matter

These dam water results indicate no restrictions or concerns for irrigation or stock watering. According to the reference ' A Producers Guide to Starting a Small Beef Feedlot in NSW' the dam water triggers none of the water quality guidelines and in fact the water a far higher quality than these limits specified.

RIVER WATER

The water quality of the Beardy River adjacent to the Feedlot (sample 2 of job i3094) is considered of fairly good water quality characterised by

- Moderately alkaline pH
- Slightly elevated salinity (ie. total dissolved salts) showing significant groundwater influence and not rain water fed
- Moderate high suspended solids hence clarity not particularly good with likely fine clay particulates
- Moderate water hardness and alkalinity showing a dominance of the salts by bicarbonate and calcium and magnesium
- Very low dissolved phosphate phosphorus but marginally elevated total phosphorus related to the suspended matter
- Slightly elevated total nitrogen from the suspended matter but low nitrogen species with only slightly elevated ammonium
- Low breakdown of salts dominated by calcium and very low SAR

Very low chloride and sulfate

- Slightly elevated bacteria as indicated by the Faecal coliforms
- Low metals dominated by iron, aluminium and manganese all likely related to the clay in the suspended matter

These river water results indicate no restrictions or concerns for irrigation or stock watering. According to the reference 'A Producers Guide to Starting a Small Beef Feedlot in NSW' the river water triggers none of the water quality guidelines and in fact the water a far higher quality than these limits specified.

GROUND WATER

The water quality of the groundwater (Windmill Hole) near the Feedlot (sample 3 of job i3094) is considered of fairly good water quality characterised by

- Moderately alkaline pH
- Marginally elevated salinity (ie. total dissolved salts)
- Elevated suspended solids hence clarity not particularly good with likely fine clay particulates
- High water hardness and alkalinity showing a dominance of the salts by bicarbonate and calcium and magnesium
- Very low phosphorus
- Slightly elevated total nitrogen from the suspended matter but low nitrogen species
- Low breakdown of salts dominated by calcium and magnesium and very low SAR
- Very low chloride and sulfate
- Non detected bacteria as indicated by the Faecal coliforms
- Low metals with only slightly elevated iron, aluminium and manganese all likely related to the clay in the suspended matter

These dam water results indicate no restrictions or concerns for irrigation or stock watering. According to the reference 'A Producers Guide to Starting a Small Beef Feedlot in NSW' the ground water triggers none of the water quality guidelines and in fact the water a far higher quality than these limits specified.

Regards

Graham

Graham Lancaster BAppSc(Hons)(UNENR)
Laboratory Director/Manager

Environmental Analysis Laboratory

T 02 6620 3678 **M** 0419 984 088

signature_1634303131



LISMORE CAMPUS

Military Road, East Lismore NSW 2480

From: O Pedlow <opedlow@highlandcourt.com.au>
Date: Tuesday, 20 August 2019 at 2:57 pm
To: Graham Lancaster <Graham.Lancaster@scu.edu.au>
Subject: Re water sample summary for Jardana Feedlot

Hi Graham

Just wondering if you have had time to put together a brief summary of the water test results yet.

regards

Kaylene Pedlow

*Kaylene A Pedlow
Highland Court Angus*



Virus-free. www.avg.com

RESULTS OF WATER ANALYSIS

3 samples supplied by Jardana Pty Ltd on 24th June, 2019. Lab Job No. i3093

Samples submitted by Owen Pedlow. Your Job: Water testing

34 Pedlows Road GLEN INNES

Parameter	Methods reference	Sample 1	Sample 2	Sample 3
		Dam Above Feedlot	Beardy River	Windmill Hole
	<i>Job No.</i>	<i>i3093/1</i>	<i>i3093/2</i>	<i>i3093/3</i>
pH	APHA 4500-H ⁺ -B	7.88	7.68	7.96
Conductivity (EC) (dS/m)	APHA 2510-B	0.195	0.446	0.721
Total Dissolved Salts (mg/L)	** Calculation using EC x 680	133	303	490
Total Suspended Solids (mg/L)	GFC equiv. filter - APHA 2540-D	24	148	34
Bicarbonate (Alkalinity) (mg/L CaCO ₃ equivalent)	** Total Alkalinity - APHA 2320	78	170	430
Water Hardness (mg/L CaCO ₃ equivalent)	** Using Ca and Mg calculation	81	172	377
Total Phosphorus (mg/L P)	In house method W4	0.07	0.81	0.19
Phosphate (mg/L P)	APHA 4500 P-G	<0.005	0.018	0.014
Total Nitrogen (mg/L N)	In house method W4	2.09	12.10	2.11
Total Kjeldahl Nitrogen (mg/L N)	** Calculation: TN – NO _x	1.50	12.09	2.02
Nitrate (mg/L N)	APHA 4500 NO ₃ -F	0.574	0.007	0.090
Nitrite (mg/L N)	APHA 4500 NO ₂ -I	0.010	<0.005	0.008
Ammonia (mg/L N)	APHA 4500 NH ₃ -H	0.442	1.023	0.317
Sodium (mg/L)	APHA 3125 ICPMS ^{note 1&2}	6.6	28.0	17.2
Potassium (mg/L)	APHA 3125 ICPMS ^{note 1&2}	6.5	7.1	1.8
Calcium (mg/L)	APHA 3125 ICPMS ^{note 1&2}	16.7	27.8	78.4
Magnesium (mg/L)	APHA 3125 ICPMS ^{note 1&2}	9.5	25.0	44.1
Sodium Absorption Ratio (SAR)	** By calculation	0.3	0.9	0.4
Chloride (mg/L)	APHA 3125 ICPMS ^{note 1&2}	12	35	18
Sulfate (mg/L SO ₄ ²⁻)	APHA 3125 ICPMS ^{note 1&2}	2.7	18.9	4.3
Chloride/Sulfate Ratio	** Calculation	4.4	1.9	4.1
Faecal Coliforms (cfu/100 ml)	** APHA 9222-D	230	300	<10
Silver (mg/L)	Total Available - APHA 3125 ICPMS ^{note 1&2}	<0.001	<0.001	<0.001
Aluminium (mg/L)	Total Available - APHA 3125 ICPMS ^{note 1&2}	0.506	0.563	0.091
Arsenic (mg/L)	Total Available - APHA 3125 ICPMS ^{note 1&2}	<0.001	<0.001	<0.001
Cadmium (mg/L)	Total Available - APHA 3125 ICPMS ^{note 1&2}	<0.001	<0.001	<0.001
Chromium (mg/L)	Total Available - APHA 3125 ICPMS ^{note 1&2}	<0.001	<0.001	<0.001
Copper (mg/L)	Total Available - APHA 3125 ICPMS ^{note 1&2}	0.004	0.004	<0.001
Iron (mg/L)	Total Available - APHA 3125 ICPMS ^{note 1&2}	0.907	1.716	0.302
Manganese (mg/L)	Total Available - APHA 3125 ICPMS ^{note 1&2}	0.106	0.824	0.237
Nickel (mg/L)	Total Available - APHA 3125 ICPMS ^{note 1&2}	0.010	0.012	0.002
Lead (mg/L)	Total Available - APHA 3125 ICPMS ^{note 1&2}	<0.001	<0.001	<0.001
Selenium (mg/L)	Total Available - APHA 3125 ICPMS ^{note 1&2}	<0.002	<0.002	<0.002
Zinc (mg/L)	Total Available - APHA 3125 ICPMS ^{note 1&2}	0.002	0.005	<0.001
Mercury (mg/L)	Total Available - APHA 3125 ICPMS ^{note 1&2}	<0.0005	<0.0005	<0.0005

Notes:

- Total metals - samples digested with nitric acid; Total available (acid soluble/ extractable) metals - samples acidified with nitric acid to pH <2; Dissolved metals - samples filtered through 0.45µm cellulose acetate and then acidified with nitric acid prior to analysis
- Metals and salts analysed by Inductively Coupled Plasma - Mass Spectrometry (ICP-MS).
- 1 mg/L (milligram per litre) = 1 ppm (part per million) = 1000 µg/L (micrograms per litre) = 1000 ppb (part per billion).
- For conductivity 1 dS/m = 1 mS/cm = 1000 µS/cm.
- Analysis performed according to APHA (2017) 'Standard Methods for the Examination of Water & Wastewater', 23rd Edition, except where stated otherwise.
- Analysis conducted between sample arrival date and reporting date.
- ** NATA accreditation does not cover the performance of this service.
- ... Denotes not requested.
- This report is not to be reproduced except in full.
- All services undertaken by EAL are covered by the EAL Laboratory Services Terms and Conditions (refer scu.edu.au/eal or on request).
- Results relate only to the samples tested.
- This report was issued on 03/07/2019.



APPENDIX H – BIOSECURITY MANAGEMENT PLAN



Local Land Services
Northern Tablelands

Farm Biosecurity Plan

Hotline Numbers

24-hour Emergency Animal Disease Watch Hotline: **1800 675 888**
Exotic Plant Pest Hotline: **1800 084 881**
Lifeline: **13 11 14**
WIRES: **1300 094 737**

How to contact us:

Call **1300 795 299** to contact your Local Land Services office from Monday to Friday during business hours.
All offices are contactable via email at admin.northerntablelands@lls.nsw.gov.au

Inverell Office

T: 02 6720 8300
F: 02 6720 8398
15 Vivian Street
PO Box 411
Inverell NSW 2360

Armidale Office

T: 02 6770 2000
F: 02 6772 7274
126-130 Taylor Street
Armidale NSW 2350

Glen Innes Office

T: 02 6732 8800
F: 02 6732 1420
1 Greenaway Street
Glen Innes NSW 2370

Tenterfield Office

T: 02 6739 1400
F: 02 6736 2614
142 High Street
Tenterfield NSW 2372



Local Land Services
Northern Tablelands

www.lls.nsw.gov.au/northerntablelands

Protecting

- You
- Your Animals
- Your Family
- Your Future
- Your Community
- Your Markets



Principles that Farm Biosecurity Plans need to consider

1 PRE PURCHASE

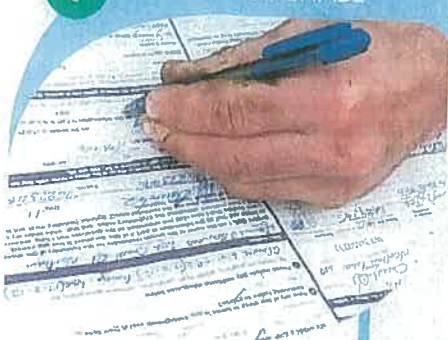

2 ON ARRIVAL



3 ON FARM



SITUATION	ACTION
When introducing animals on farm	<ul style="list-style-type: none"> Demand a National Vendor Declaration (NVD) and Health Statements Read the documents before you buy the stock File NVDs and Health Statements Ensure stock are transferred on the NLIS database
When purchasing feed (hay, grain or supplements)	<ul style="list-style-type: none"> Demand a Commodity Vendor Declaration (CVD) Record batch numbers and product details Check feed for weeds on arrival Understand "Swill Feeding" prohibition Do not feed "Restricted Animal Matter" to cattle or sheep File CVD and feed purchase records
When chemicals are purchased	<ul style="list-style-type: none"> Record chemical name, batch number and withhold periods (WHPs) Store according to label Read the label on all chemicals
When people visit your property	<ul style="list-style-type: none"> Let people know your biosecurity standards Place biosecurity signs at your front gates
When machinery is delivered on farm	<ul style="list-style-type: none"> Make sure it is clean Record where it was delivered from
When contractors are inducted	<ul style="list-style-type: none"> Explain your biosecurity expectations Include WH&S briefing
Livestock on arrival	<ul style="list-style-type: none"> Ensure all animals have an NLIS device Undertake induction treatments and record them Keep new stock separated for at least 21 days If animals are ill during this period contact your veterinarian and agent Check stock regularly during quarantine period Have a Biosecurity Plan for each part of your enterprise. ASK US!!
Livestock on farm	<ul style="list-style-type: none"> Record treatments and date animals are treated Have a vaccination program Have an internal parasite program Investigate animals in poor health
Pests on farm	<ul style="list-style-type: none"> Secure boundary fences and check regularly Be part of a pest control group Record pest control activities Notify neighbours when baiting
Weeds on farm	<ul style="list-style-type: none"> Check feed out sites for weeds and record where weeds are found Check boundaries for weeds and work with neighbours
Water	<ul style="list-style-type: none"> Check troughs and dams regularly Test water if unsure of the quality
Rubbish and waste	<ul style="list-style-type: none"> Dispose of rubbish and waste at a registered facility Fence off dips and old dumps
Training	<ul style="list-style-type: none"> Ensure staff and contractors understand your Biosecurity Plan Keep records of training and use trained staff Ensure staff are vaccinated for tetanus, Q Fever
Boundary fences	<ul style="list-style-type: none"> Inspect and maintain boundary fences
Selling livestock	<ul style="list-style-type: none"> Complete National Vendor Declaration Record PICs correctly Record treatments Ensure all stock have an NLIS device



To create a Farm Biosecurity Plan

- Include the actions on this page in your farm management
- Record your activities
- File all documents of activities and actions relating to your Farm Biosecurity Plan
- Call us if you would like an enterprise specific plan

Property name Elms Court Property
 PIC NB250484

Property owner's name Jardana Pty Ltd
 Manager Owen Redlow

Start date for plan 7-6-17

Signed by owner/manager Owen Redlow

Seen 7-6-17
by a BOWEN
D.V. [unclear] [unclear]



Emergency Animal Disease (EAD) Action Plan

www.farmbiosecurity.com.au

This document details the actions (and responsibilities) that are to be undertaken in the event that an emergency disease outbreak is suspected within the feedlot.

[A] Important Contact Details

	Name	Contact Number
Feedlot Name	JARDANA PTY LTD	(02)67323886
Feedlot Manager	OWEN PEDLOW	0427007685
Person responsible for the EAD Action Plan	OWEN PEDLOW	AS ABOVE
Consultant Veterinarian	GLEN INNES VETERINARY CLINIC (02)67321988	
District Veterinary Officer	LOCAL LANDS SERVICE	
Emergency Disease Hotline	1800 675 888	

[B] Management Commitment

Feedlot management undertakes that unfamiliar diseases will be investigated and the following actions undertaken without delay if an emergency disease is suspected.

[C] Action Plan

Develop an action plan allocating responsibilities to relevant personnel.

- Contact consultant veterinarian and the relevant authority through the District Veterinary Officer or the Exotic Disease Hotline.
Responsibility: OWEN PEDLOW (OWNER/MANAGER)
- The Feedlot will follow all instructions as directed by the Relevant Authority.
Responsibility: OWEN PEDLOW (OWNER/MANAGER)
- Do not dispatch cattle from the feedlot site until authorised by the relevant authority.
Responsibility: OWEN PEDLOW (OWNER/MANAGER)
- Ensure suspected cattle are isolated within the feedlot.
Responsibility: OWEN PEDLOW
- Ensure companion animals of the suspect cattle are segregated from other cattle.
Responsibility: OWEN PEDLOW
- Ensure movement of all other cattle within the feedlot complex and surrounds is restricted.
Responsibility: OWEN PEDLOW
- Delay or halt the shipment of cattle onto the feedlot site.
Responsibility: OWEN PEDLOW
- Delay or halt the delivery of all non-essential commodities.
Responsibility: OWEN PEDLOW
- Secure the feedlot perimeter limiting access to the feedlot site ensuring that all vehicles and visitors only enter the feedlot under controlled conditions.
Responsibility: OWEN PEDLOW
- Remove unnecessary personnel and machinery from the cattle feeding and holding areas.
Responsibility: OWEN PEDLOW
- Ensure that any personnel, equipment or machinery do not leave the feedlot site until authorised by the relevant authority.
Responsibility: OWEN PEDLOW
- Compile a list of all cattle (number of head, identification, and location), personnel and machinery movements over the past seven days. Prepare a site plan that details current pen allocations.
Responsibility: OWEN PEDLOW
- Ensure all staff are made aware of the actions being taken (staff meeting) and their individual responsibilities in regards to complying with this action plan.
Responsibility: OWEN PEDLOW
- Ensure that customers are advised if they are immediately affected by the delay in supplying cattle.
Responsibility: OWEN PEDLOW
- If an emergency disease is identified the feedlot will follow the AUSVETPLAN and directions from the relevant authority as detailed in the Contingency Planning procedure.
Responsibility: OWEN PEDLOW

If you see anything unusual on your property call the Emergency Animal Disease Watch Hotline on **1800 675 888** or the Exotic Plant Pest Hotline on **1800 084 881**



Visitor/Staff Risk Assessment

www.farmbiosecurity.com.au

Date: Visitors Name:
 Service or Occupation: Contact Number:
 Time In: Time Out:
 Reason for Visit:

Farm visitors can be classified by the risk they represent: What are you?

	Low-Risk Visitors	Come from urban areas and do not contact livestock. They present almost no risk of introducing disease No need to impose restrictions
	Moderate-Risk Visitors	Are those people that travel from farm-to-farm, but do not directly come in contact with livestock or manure Need to ensure footwear/clothing are clean
	High-Risk Visitors	Are those people that travel from farm-to-farm and work directly with livestock or manure. These people must be the most diligent with their biosecurity practices Need to ensure footwear/clothing is cleaned and disinfected or clean footwear/clothing is provided before access to animals is permitted
Comments:		

Date: Visitors Name:
 Service or Occupation: Contact Number:
 Time In: Time Out:
 Reason for Visit:

Farm visitors can be classified by the risk they represent: What are you?

	Low-Risk Visitors	Come from urban areas and do not contact livestock. They present almost no risk of introducing disease No need to impose restrictions
	Moderate-Risk Visitors	Are those people that travel from farm-to-farm, but do not directly come in contact with livestock or manure Need to ensure footwear/clothing are clean
	High-Risk Visitors	Are those people that travel from farm-to-farm and work directly with livestock or manure. These people must be the most diligent with their biosecurity practices Need to ensure footwear/clothing is cleaned and disinfected or clean footwear/clothing is provided before access to animals is permitted
Comments:		

If you see anything unusual on your property call the Emergency Animal Disease Watch Hotline on **1800 675 888** or the Exotic Plant Pest Hotline on **1800 084 881**

APPENDIX 1: Biosecurity self-audit checklist for continuous improvement

1.0 Manage Inputs – stock, water, feed, bedding				
Reference	1.1 Cattle	Yes	No	Comments
1.1.1	Where practicable, is feeder stock purchased from preferred suppliers who maintain a quality assurance program that includes a biosecurity component?	<input type="checkbox"/>	<input type="checkbox"/>	
1.1.2	Are all cattle inspected on arrival at the feedlot to assess their animal health status? Is a record of inspection maintained?	<input type="checkbox"/>	<input type="checkbox"/>	
1.1.3	Do all vendors provide a fully completed National Vendor Declaration (NVD) and where possible, provide a National Cattle Health Statement for the consigned cattle?	<input type="checkbox"/>	<input type="checkbox"/>	
1.1.4	Are all cattle NLIS identified and transferred to the feedlot's property identification code (PIC) for trace purposes?	<input type="checkbox"/>	<input type="checkbox"/>	
1.1.5	Where possible, is the mixing of newly arrived or returning cattle with other stock minimised?	<input type="checkbox"/>	<input type="checkbox"/>	
Reference	1.2 Horses	Yes	No	Comments
1.2.1	Are all horses retained on the property for a minimum period of two weeks after working with cattle in order to allow any signs of disease to be seen before they are transferred off the property? Alternatively, are horses kept separated from other horses when returning to their home property?	<input type="checkbox"/>	<input type="checkbox"/>	
1.2.2	Is a horse register maintained to record movement of all horses on and off the feedlot site?	<input type="checkbox"/>	<input type="checkbox"/>	

APPENDIX N (0)

Reference	1.3 Water	Yes	No	Comments
1.3.1	Is a suitable water supply used? (In general, water with a high level of organic matter is unsuitable.) Has expert advice been sought to ensure a safe water supply?	<input type="checkbox"/>	<input type="checkbox"/>	
1.3.2	Does the drinking water for cattle meet appropriate standards as recommended by the National Guidelines for Beef Cattle Feedlots in Australia, 3rd Edition?	<input type="checkbox"/>	<input type="checkbox"/>	
1.3.3	Is expert advice sought on water treatment options when water testing shows the available water to be of unsuitable quality?	<input type="checkbox"/>	<input type="checkbox"/>	
1.3.4	If water treatment is used, is the method regularly monitored for effectiveness?	<input type="checkbox"/>	<input type="checkbox"/>	
1.3.5	Is the treated water supply kept in a closed system from the point of treatment to the point of drinking?	<input type="checkbox"/>	<input type="checkbox"/>	
Reference	1.4 Feed	Yes	No	Comments
1.4.1	Where practicable, are feed commodities purchased from preferred suppliers who maintain a quality assurance program that includes a biosecurity component?	<input type="checkbox"/>	<input type="checkbox"/>	
1.4.2	Is the ban on feeding of animal products (ruminant feed ban) to cattle complied with? Is restricted animal material (RAM) not fed to cattle (or any other ruminants), including any material that may contain or may have been in contact with RAM? (There are specific regulations in each state prohibiting the feeding of RAM.)	<input type="checkbox"/>	<input type="checkbox"/>	
1.4.3	Is feed stored in a manner that reduces contamination by livestock, vermin, insects, wildlife, feral and domestic animals and other feed types?	<input type="checkbox"/>	<input type="checkbox"/>	

1.4.4	Are feed commodities fit for purpose? Is all purchased feed accompanied by a commodity/by-product vendor declaration stating that it is free from chemical residues/contaminants and fit for the purpose of feeding to beef cattle?	<input type="checkbox"/>	<input type="checkbox"/>	
1.4.5	Are feed spills cleaned up as soon as practicable? (Spilled and spoiling feed attracts pests and vermin to the feedlot.)	<input type="checkbox"/>	<input type="checkbox"/>	
Reference	1.5 Bedding	Yes	No	Comments
1.5.1	Is bedding material fit for purpose?	<input type="checkbox"/>	<input type="checkbox"/>	
1.5.2	Are areas where bedding is stored kept dry and vermin free as practically as possible?	<input type="checkbox"/>	<input type="checkbox"/>	
Comments:				

2.0 Manage the movement of people, vehicles and equipment

Reference	2.1 Feedlot employees and family	Yes	No	Comments
2.1.1	Do all feedlot personnel wear laundered clean clothes each day at the commencement of their work?	<input type="checkbox"/>	<input type="checkbox"/>	
2.1.2	Are boots worn at the feedlot not worn or taken outside the feedlot unless clean? (This is the most likely method of diseases being spread by personnel.)	<input type="checkbox"/>	<input type="checkbox"/>	
2.1.3	Are protective clothing and footwear worn in the feedlot hospital pens area at all times and removed prior to exiting?	<input type="checkbox"/>	<input type="checkbox"/>	
2.2.4	Are hands sanitised on leaving the feedlot hospital pens?	<input type="checkbox"/>	<input type="checkbox"/>	
Reference	2.2 Visitors, contractors, suppliers and other service personnel	Yes	No	Comments
2.2.1	Is there an awareness of the potential for the introduction and transmission of an emergency disease by visitors?	<input type="checkbox"/>	<input type="checkbox"/>	
2.2.2	Wherever possible, is there control over the access of visitors/suppliers to the designated feedlot area?	<input type="checkbox"/>	<input type="checkbox"/>	
2.2.3	Are all visitors entering the feedlot directed to a designated meeting place away from the main feedlot area, preferably the office, before access is allowed to the main feedlot area?	<input type="checkbox"/>	<input type="checkbox"/>	
2.2.4	Is a register of visitors and vehicles (including contractors) to the feedlot maintained? The record (Appendix 3) should include: <ul style="list-style-type: none"> • date • time in • name(s) • company • contact number • motor vehicle registration number • signature • biosecurity risk assessment • time out 	<input type="checkbox"/>	<input type="checkbox"/>	

2.2.5	Are all visitors (including contractors) who enter the feedlot assessed for their biosecurity risk prior to being granted access to the feedlot complex and surrounds? Does the risk assessment consider the potential for visitors who have been previously exposed to a disease and the subsequent potential for them to introduce a disease into the feedlot? (Appendix 4)	<input type="checkbox"/>	<input type="checkbox"/>	
Reference	2.3 Equipment	Yes	No	Comments
2.3.1	Employees and contractors can use their own tools and personal equipment (e.g. laptops, cameras or phones), but do they note that the equipment must be cleaned, ensuring it is free of organic matter?	<input type="checkbox"/>	<input type="checkbox"/>	
2.3.2	Is there awareness of the potential for introduction and transmission of an emergency disease by borrowed/hired equipment?	<input type="checkbox"/>	<input type="checkbox"/>	
2.3.3	Wherever possible, is different equipment used for handling feed and manure? If the same equipment must be used for multiple purposes, are hands washed and disinfected between uses to ensure that manure does not contaminate feed commodities?	<input type="checkbox"/>	<input type="checkbox"/>	
Reference	2.4 Vehicles	Yes	No	Comments
2.4.1	Is there an awareness of the potential for introduction and transmission of an emergency disease by visiting vehicles, machinery and equipment?	<input type="checkbox"/>	<input type="checkbox"/>	
2.4.2	Are non-feedlot vehicles, machinery and equipment restricted from entering into areas of the feedlot beyond the specified delivery areas?	<input type="checkbox"/>	<input type="checkbox"/>	
2.4.3	Is there a designated parking area for vehicles not entering the production area?	<input type="checkbox"/>	<input type="checkbox"/>	
2.4.4	Do all visitors park their vehicles outside the production area, unless it is essential that the vehicle be taken on site; for example, some maintenance contractors? Are all vehicles, machinery and equipment entering the feedlot area directed to specified locations and delivery areas within the feedlot?	<input type="checkbox"/>	<input type="checkbox"/>	
2.4.5	If any vehicle is taken into the production area/s, is it assessed as to its risk and washed and disinfected prior to entry as required?	<input type="checkbox"/>	<input type="checkbox"/>	
Comments:				

3.0 Manage production practices

Reference	3.1 Livestock monitoring	Yes	No	Comments
3.1.1	Does routine monitoring occur of cattle in the feedlot for signs of illness/injury and are records maintained as part of a health management program?	<input type="checkbox"/>	<input type="checkbox"/>	
3.1.2	Are cases of unusual illness or death in the feedlot reported to the consulting veterinarian or the local government veterinary officer? <i>NFAS-accredited feedlots should refer to their EAD Action Plan.</i>	<input type="checkbox"/>	<input type="checkbox"/>	
3.1.3	Are all cattle mortalities and cases of disease recorded to assist monitoring for any unusual animal health problems potentially indicating a biosecurity breach?	<input type="checkbox"/>	<input type="checkbox"/>	
3.1.4	Is a record of cattle movements in and out of the feedlot maintained to facilitate tracing in the event of an animal health/disease or food safety concern?	<input type="checkbox"/>	<input type="checkbox"/>	
Reference	3.2 Manure and effluent management	Yes	No	Comments
3.2.1	Is there awareness that manure and effluent pose a potential biosecurity risk?	<input type="checkbox"/>	<input type="checkbox"/>	
3.2.2	Are movements of manure and/or compost removed from the feedlot site recorded?	<input type="checkbox"/>	<input type="checkbox"/>	
3.2.3	Are dates, areas of manure and effluent application and application rates recorded in accordance with the requirements of the National Beef Cattle Feedlot Environmental Code of Practice?	<input type="checkbox"/>	<input type="checkbox"/>	
3.2.4	Is there awareness that for some emergency disease outbreaks there may be a requirement under AUSVETPLAN for the mass de-contamination and disposal of manure and effluent? Has a management plan for such an event been developed?	<input type="checkbox"/>	<input type="checkbox"/>	
Reference	3.3 Dead stock management	Yes	No	Comments
3.3.1	Has dead stock been disposed of in accordance with documented procedures that satisfy the National Beef Cattle Feedlot Environmental Code of Practice, taking into account environmental and public considerations?	<input type="checkbox"/>	<input type="checkbox"/>	

3.3.2	Has dead stock been covered and placed in a pit as soon as possible to eliminate potential problems with feral animal activity?	<input type="checkbox"/>	<input type="checkbox"/>	
3.3.3	Has a management plan for the mass disposal of dead stock been developed? (The AUSVETPLAN Disposal and Feedlot Enterprise Manuals provide relevant information in this regard.)	<input type="checkbox"/>	<input type="checkbox"/>	
Reference	3.4 Maintenance	Yes	No	Comments
3.4.1	Is grass on and around the feedlot site kept cut? (Long grass attracts rodents and favours the survival of viruses and bacteria.)	<input type="checkbox"/>	<input type="checkbox"/>	
3.4.2	As much as possible, is maintenance conducted between feeding groups? Is all hardware removed in the cleanup?	<input type="checkbox"/>	<input type="checkbox"/>	
3.4.3	Are feedlot internal fences adequately maintained to minimise accidental mixing of cattle within the feedlot?	<input type="checkbox"/>	<input type="checkbox"/>	
3.4.4	Are perimeter fences adequately maintained to minimise exposure of cattle in the feedlot to stock in adjoining areas?	<input type="checkbox"/>	<input type="checkbox"/>	
Reference	3.5 Identification	Yes	No	Comments
3.5.1	Are introduced cattle identified within seven (7) days of arrival onto the feedlot?	<input type="checkbox"/>	<input type="checkbox"/>	
3.5.2	Is dual identification of individual cattle conducted to enhance traceability?	<input type="checkbox"/>	<input type="checkbox"/>	
3.5.3	Is the National Livestock Identification System (NLIS) database checked to ensure all cattle to be fed are fit for purpose?	<input type="checkbox"/>	<input type="checkbox"/>	
3.5.4	Are feedlot records regarding cattle entry, identification and exit kept?	<input type="checkbox"/>	<input type="checkbox"/>	
3.5.5	Does the feedlot adhere to the NLIS legislation of the relevant state/territory at all times?	<input type="checkbox"/>	<input type="checkbox"/>	
Comments:				

4.0 Manage feral animals, pests and vermin

Reference	4.1 Pests and vermin	Yes	No	Comments
4.1.1	Is a pest and vermin control program implemented and maintained?	<input type="checkbox"/>	<input type="checkbox"/>	
4.1.2	Are bait stations checked weekly and fresh baits set as required?	<input type="checkbox"/>	<input type="checkbox"/>	
4.1.3	Are records kept of each inspection and activity noted? (see Appendix 5)	<input type="checkbox"/>	<input type="checkbox"/>	
4.1.4	Are bait stations placed away from cattle access and designed to minimise the opportunity for other animals and birds to access the bait?	<input type="checkbox"/>	<input type="checkbox"/>	
Reference	4.2 Feral animals and wildlife	Yes	No	Comments
4.2.1	Is there awareness of the potential for introduction and transmission of an emergency disease by feral animals and wildlife?	<input type="checkbox"/>	<input type="checkbox"/>	
4.2.2	Where possible, is the potential for introduction and transmission of an emergency disease by feral animals and/or wildlife minimised?	<input type="checkbox"/>	<input type="checkbox"/>	
Comments:				

5.0 Manage outgoing products				
Reference	5.0 Manage outgoing products	Yes	No	Comments
5.0.1	Are only those animals that are in a condition fit for travel selected, to minimise potential disease and/or contamination spread through transport? (See Meat & Livestock Australia's <i>Is it fit to load?</i> guide for relevant information.)	<input type="checkbox"/>	<input type="checkbox"/>	
Comments:				

6.0 Train – plan – record				
Reference	6.1 Training	Yes	No	Comments
6.1.1	Are all employees involved in the daily monitoring and handling of stock aware of the importance of early detection of diseases and know what to do if they suspect an animal may be exhibiting symptoms of disease?	<input type="checkbox"/>	<input type="checkbox"/>	
6.1.2	Are all employees involved in the daily monitoring and handling of stock aware of the presence of best practice guidelines for specific diseases (e.g. anthrax)?	<input type="checkbox"/>	<input type="checkbox"/>	
6.1.3	Are all employees involved in the usage and application of farm disinfectants and herbicides competent to do so? (Refer to Agchem and Vetchem training.)	<input type="checkbox"/>	<input type="checkbox"/>	
Reference	6.2 Documentation and record keeping	Yes	No	Comments
6.2.1	Is there a sketch or map of the layout of the property, showing the production area, sheds, paddocks, access roads and gates and is it maintained up to date?	<input type="checkbox"/>	<input type="checkbox"/>	
6.2.2	Are records and documentation maintained in line with all sections of the National Biosecurity Manual for Beef Cattle Feedlots?	<input type="checkbox"/>	<input type="checkbox"/>	

**EMERGENCY ANIMAL
 DISEASE WATCH HOTLINE
 1800 675 888**

APPENDIX I – HEAT LOAD RISK ASSESSMENT

RISK ANALYSIS PROGRAM (RAP)

Helping define the local risk of Heat Load in your cattle

RAP Version 2.1 | 28th July 2019

Results

Results calculated on 2019-07-28 04:56:18 AM

HLI threshold: 86

AHLU Risk Level: 86

Years analysed: 22

Event duration	Frequency of High	Frequency of Extreme
2 days	Less than 1 event in 22 years	Less than 1 event in 22 years
3 days	Less than 1 event in 22 years	Less than 1 event in 22 years
4 days	Less than 1 event in 22 years	Less than 1 event in 22 years
5 days	Less than 1 event in 22 years	Less than 1 event in 22 years
6 days	Less than 1 event in 22 years	Less than 1 event in 22 years
7 or more days	Less than 1 event in 22 years	Less than 1 event in 22 years

Over a 10 year period, this site would be expected to experience:

At least 0 days of high or greater risk that includes 0 days of extreme risk

Parameters

Parameter	Value
Site	Glen Innes Airport

Period analysed	Long Term
Cattle type	Bos taurus
Coat colour	Black
Health status	Healthy
Number of days on feed	80 - 130
Amount of shade	No shade
Trough water temperature	20 - 30 degrees
Pen class	Class 1
Extra water troughs installed	No
Heat load ration fed	No
Wet manure removal	No
User Notes	

APPENDIX J – TRAFFIC IMPACT ASSESSMENT



Traffic Impact Assessment

34 Pedlows Road, Stonehenge NSW 2370

September 2020



Type of Assessment: Traffic Impact Assessment

Site Location: 34 Pedlows Road, Stonehenge NSW 2370

Prepared for: Owen Pedlow (Jardana Pty Ltd)

Prepared by: APEX Engineers

ABN 52 487 919 980

www.apexengineers.com.au

Document Control

Version	Author	Date Released
2.0	<i>Supun Perera</i> Supun (Sam) Perera BE (Hons), MS NER, RPEQ MIEAust, M.AITPM	17 September 2020

Disclaimer

This report has been prepared on the basis of information available at the date of publication. APEX Engineers will not be liable for any loss, damage, cost or expense incurred or arising by reason of any person relying on information in this report. Reproduction of this report or any part is not permitted without prior written consent of APEX Engineers.

© Copyright 2020 by APEX Engineers

TABLE OF CONTENTS

1. Introduction.....	4
2. Background and Existing Conditions	4
3. Traffic Generation Estimates	7
4. Sight Distance Availability	9
5. B-Double Vehicle Manouverability Conditions.....	11
6. Conclusions.....	12
Appendix A: Swept Path Results for a 19m B-Double Vehicle	13

LIST OF FIGURES AND TABLES

Figure 1: Location of the subject site	5
Figure 2: Access route to the site off New England Highway.....	5
Figure 3: New England Highway/Stonehenge Road Intersection	6
Figure 4: Restricted Access Vehicle map for the site vicinity	7
Table 1: Anticipated light and heavy vehicle traffic generation levels.....	8
Figure 5: Sight distance requirements at access driveway exits (AS 2890.2).....	9
Figure 6: Sight distance availability for vehicles exiting Stonehenge Road.....	10

1. INTRODUCTION

APEX Engineers were engaged by Owen Pedlow (Jardana Pty Ltd) to provide a traffic impact assessment as a part of the development application for the proposed cattle feedlot development at 34 Pedlows Road, Stonehenge NSW 2370.

This report has been structured into the following sections:

- **Section 2** Describes the existing transport conditions in the locality and provides an overview of the proposed development;
- **Section 3** Provide an estimate of the anticipated light and heavy vehicle traffic generation levels associated with the proposed development;
- **Section 4** Provide a review of the sight distance availability at the New England Highway/Stonehenge Road intersection;
- **Section 5** Illustrates the swept paths, at the New England Highway/Stonehenge Road intersection, for the largest vehicle anticipated to access the subject site; and
- **Section 6** Provides the summary and conclusions of the study.

2. BACKGROUND AND EXISTING CONDITIONS

The subject site is located at 34 Pedlows Road in Stonehenge and is zoned as primary production (RU1). The site vicinity is characterised by rural undeveloped land. Vehicle access to the site is provided off New England Highway (A state controlled, 'classified' road), through Stonehenge Road and Pedlows Road. At the intersection with Stonehenge Road, New England Highway includes a single carriageway (i.e. one traffic lane in each direction) with a 100 km/hr speed limit.

Figure 1 below highlights the site location from an aerial perspective.

Figure 2 illustrates the vehicle route to the subject site from New England Highway

Figure 3 shows the New England Highway/Stonehenge Road intersection from a street view perspective.

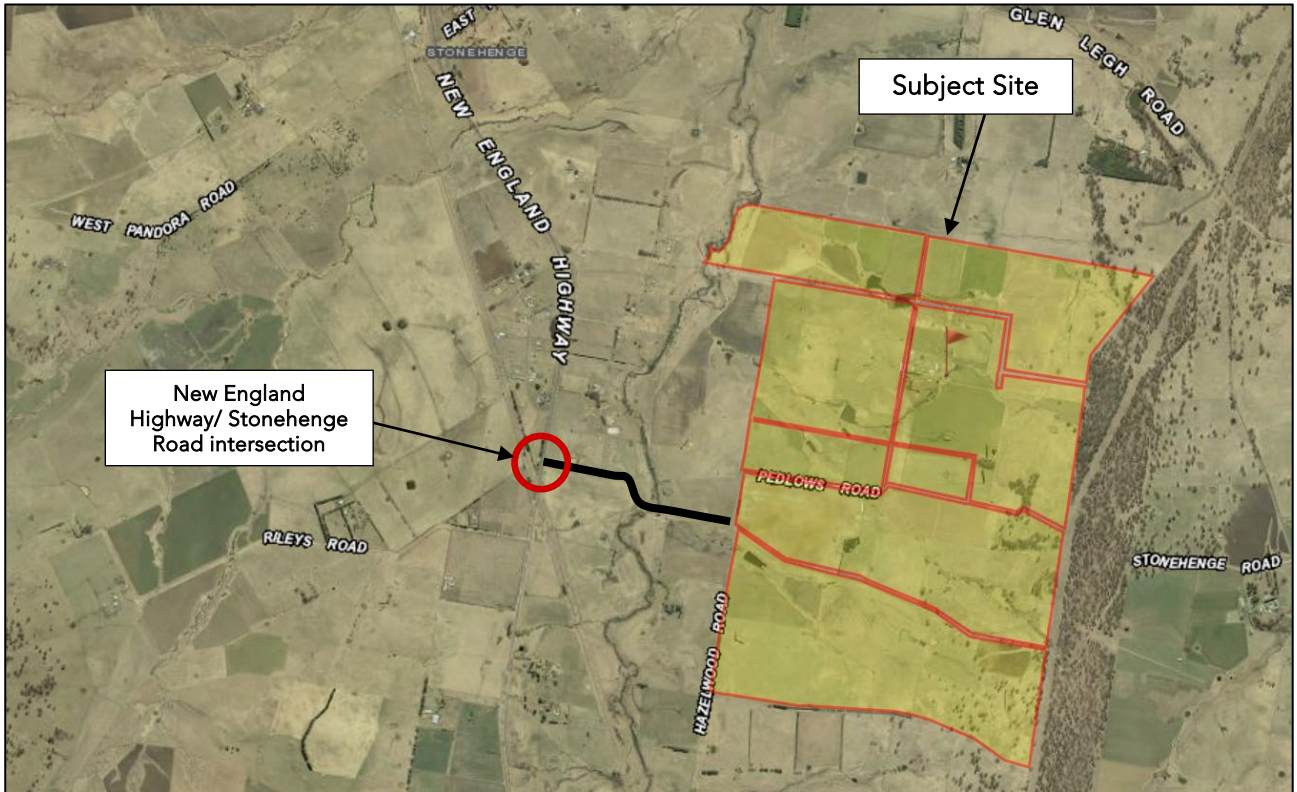

Figure 1: Location of the subject site



Figure 2: Access route to the site off New England Highway



Figure 3: New England Highway/Stonehenge Road Intersection

3. TRAFFIC GENERATION ESTIMATES

Vehicles will access the proposed cattle feedlot at 34 Pedlows Road from the New England Highway, via Stonehenge Road. The largest vehicle anticipated to access the site is a 19m B-Double vehicle. **Figure 4** below illustrates the routes that have been approved for B-Double vehicles (up to 25m long), within the site locality. Note that this map is obtained from the RMS Restricted Access Vehicles map. As can be seen, New England Highway (leading towards and away from the Stonehenge Road intersection) is an approved B-Double route.

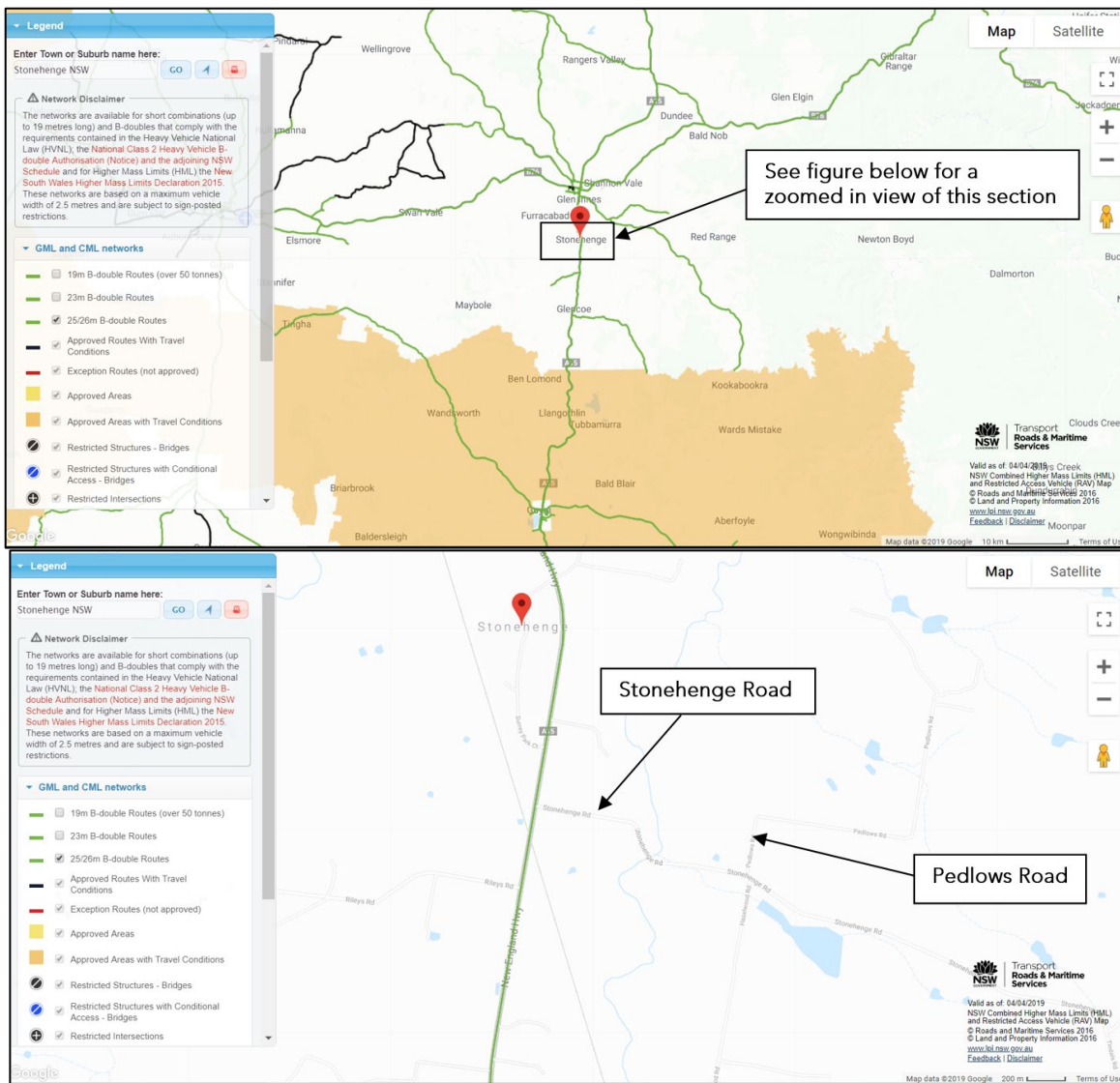

Figure 4: Restricted Access Vehicle map for the site vicinity

The following table outlines the anticipated light and heavy vehicle traffic generation levels expected to be realised due to the operations of the proposed development.

Table 1: Anticipated light and heavy vehicle traffic generation levels

Vehicle type	Movements per day	Movements per week	Route
Passenger vehicle (light vehicle)	2 movements (i.e. 1 in and 1 out)	14 movements (i.e. 7 in and 7 out)	North and southbound on New England Highway for both entry and exit movements
Rigid Truck (8.8m long Medium Rigid Vehicle)	N/A	6 movements (i.e. 3 in and 3 out)	
B-Double (19m long Articulated Vehicle)	N/A	6 movements (i.e. 3 in and 3 out)	

With reference to the information presented in the table above, the following should be noted;

- The single passenger vehicle trip (daily) is representative of the feedlot operator’s trips to the site in the morning and out of the site in the evening.
- The 3 medium rigid vehicle trips (per week) relate to various deliveries (including during the construction stage – however, it is noted that the majority of the required infrastructure is currently in place, thus the construction phase is not expected to last for more than a month)
- The 3 x 19m B-Double trips (per week) relate to delivery of livestock and grains, respectively.
- Haulage of manure is not required as manure will be placed within the farm site.

It is noted that the deliveries by B-Double vehicle will occur after 9am and before 2.30pm, on weekdays. This time period avoids the school opening and closing times, so that school bus services are not interrupted due to the B-Double truck movements. The above delivery time restriction may be conditioned as a part of the development consent.

4. SIGHT DISTANCE AVAILABILITY

In order to assess the sight distance availability for vehicles exiting Stonehenge Road onto New England Highway, the sight distance requirements stipulated in AS 2890.2 has been adopted (as shown in the figure below).

Note that in this assessment, Stonehenge Road is considered as the access driveway with the frontage road as the New England Highway. The distances outlined in the figure below are equivalent to minimum gap sight distance (as stipulated in AS 2890.2).

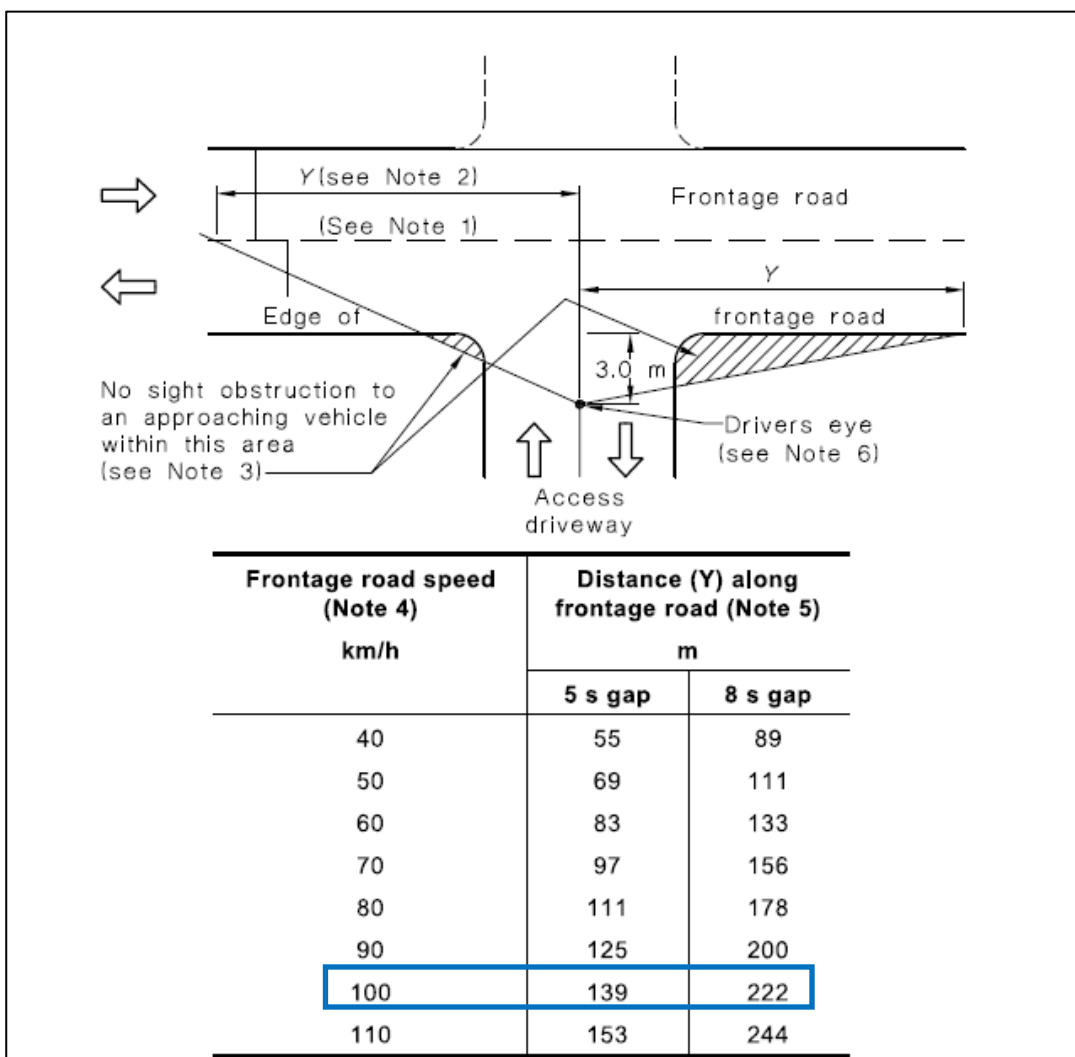

Figure 5: Sight distance requirements at access driveway exits (AS 2890.2)

Considering the 100 km/h speed limit on New England Highway, in order for the drivers exiting Stonehenge Road onto New England Highway to obtain a 5 second gap, they will require 139m distance (to the left and right hand sides, along the centre of each travel lane on New England Highway) to be clear of obstructions when standing 3m behind the edge of New England Highway. The following aerial image illustrates the above discussed sight distance requirement.

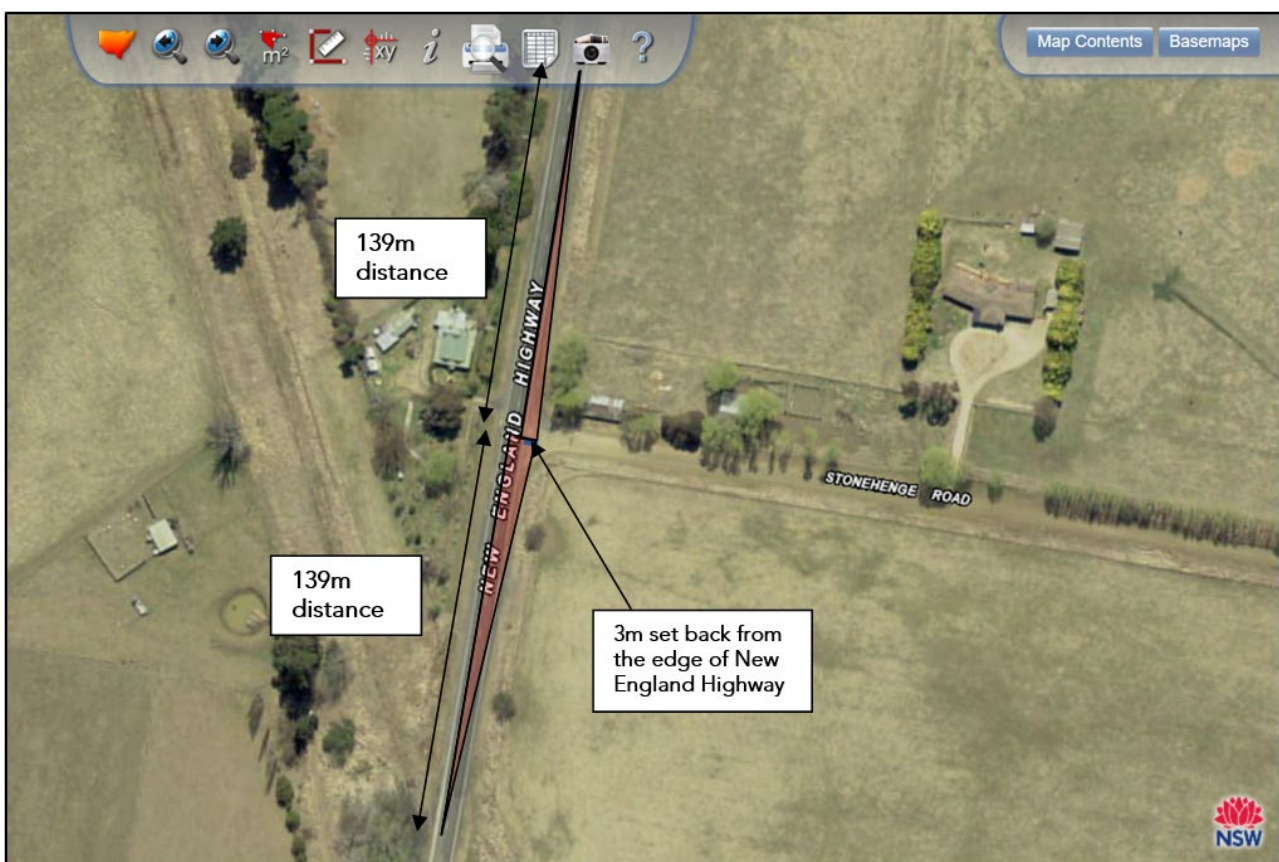

Figure 6: Sight distance availability for vehicles exiting Stonehenge Road

As can be seen from the figure above, a vehicle exiting Stonehenge Road onto New England Highway can conveniently obtain the required 139m sight envelop (to both left- and right-hand sides) when standing 3m away from the edge of New England Highway. In particular, the sight envelopes to both the left- and right-hand sides (indicated in the above figure in Red shading), are free of any obstructions. Furthermore, the straight alignment of New England Highway at this location further enhances the sight distance availability for vehicles exiting Stonehenge Road.

5. B-DOUBLE VEHICLE MANOUEVRABILITY CONDITIONS

The largest vehicle anticipated to access the proposed site, through the New England Highway/Stonehenge Road intersection, is a 19m B-Double vehicle. In order to investigate the anticipated manoeuvrability conditions of this vehicle at the New England Highway/Stonehenge Road intersection, swept path assessments were undertaken using a 19m B-Double vehicle template (with AutoTURN software - the industry standard vehicle swept path assessment software)

Appendix A of this report provides the results of this swept path assessment (for all anticipated entry and exit movements of the B-Double vehicle), overlaid on a scaled aerial image of the subject intersection. It is noted that the Blue and Cyan colour lines in the swept paths indicate the front and rear tyre tracks of the vehicle, respectively, while the Black colour of the swept paths indicate the vehicle body envelop (the Green arrows indicate the centreline of the vehicle travel path while the Red lines indicate the 500mm body clearance envelop for the vehicle).

It is evident from the results of this swept path assessment that the subject intersection can sufficiently accommodate all anticipated movements by a 19m B-Double vehicle, within the existing constraints.

6. CONCLUSIONS

APEX Engineers were engaged by Owen Pedlow (Jardana Pty Ltd) to provide a traffic impact assessment as a part of the development application for the proposed cattle feedlot development at 34 Pedlows Road, Stonehenge NSW 2370.

As outlined in this report, the anticipated light and heavy vehicle traffic generation levels from the proposed development is minimal and is unlikely to have any adverse impacts on the existing traffic conditions within the site vicinity. In particular, the deliveries through 19m B-Double vehicles (which will occur three times every week), can be conditioned to be restricted between 9am and 2.30pm, so that any interactions with the school buses operating in the area can be avoided.

The sight distance test carried out illustrates sufficient sight distance availability for the vehicles exiting onto New England Highway from Stonehenge Road. The swept path results illustrate that the New England Highway/Stonehenge Road intersection can sufficiently accommodate all anticipated movements by a 19m B-Double vehicle, within its existing constraints.

As per the above, the proposed development is unlikely to have any adverse impacts on the existing traffic conditions within the site locality.



APPENDIX A: SWEEP PATH RESULTS FOR A 19M B-DOUBLE VEHICLE



Start new ✕

Distance ?

28.29 m 📄

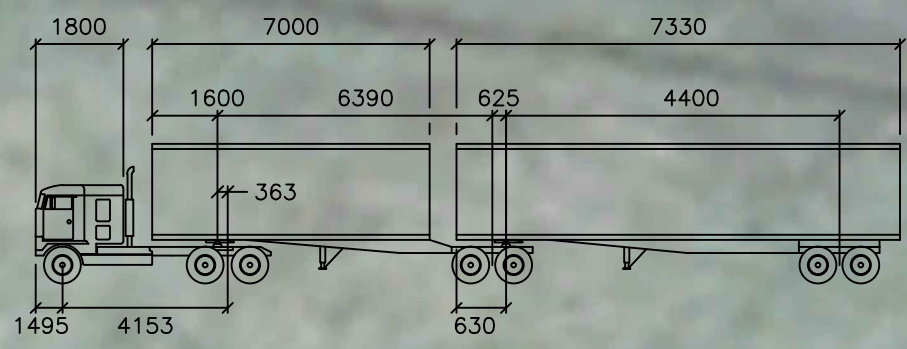
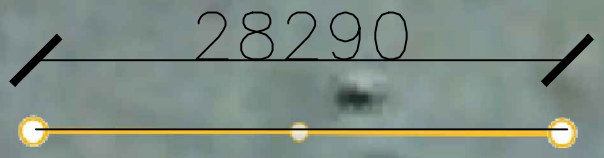

B-DOUBLE 19M mm

Tractor Width	: 2490	Lock to Lock Time	: 6.0
Trailer Width	: 2600	Steering Angle	: 19.4
Tractor Track	: 2490	Articulating Angle	: 70.0
Trailer Track	: 2600		

Google ^{AU}

3D 🌐

📏 📍

REV. NO.	DESCRIPTION TO REVISION	REV. BY	DATE

Supun Perera

Supun Perera
BE (Hons), MS,
NER, RPEQ, MIEAust, MAITPM
Traffic and Transport Engineer on behalf of APEX Engineers
 Mobile: 041 6137635, Email: Info@apexengineers.com.au



CUSTOMER: Owen Pedlow (Jardana Pty Ltd)

PROJECT: 34 Pedlows Road, Stonehenge

PROJECT PORTION				19m B-Double Vehicle Swept Path Test	
CHECKED PROPOSAL	APPROVED PROPOSAL	CLIENT APPROVED	ENGINEER APPROVED	DRG No.	REV. 1.0
DRAWN BY:	SCALE: N/A	A1	REFERENCE TO:		

Start new ✕

Distance ?
28.29 m ▾ 📄

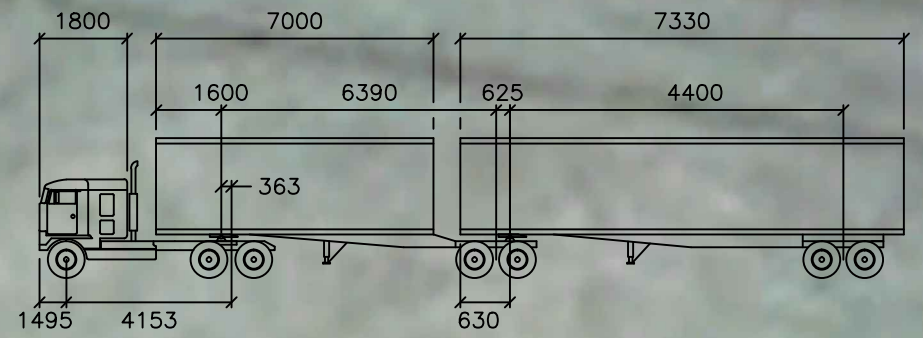
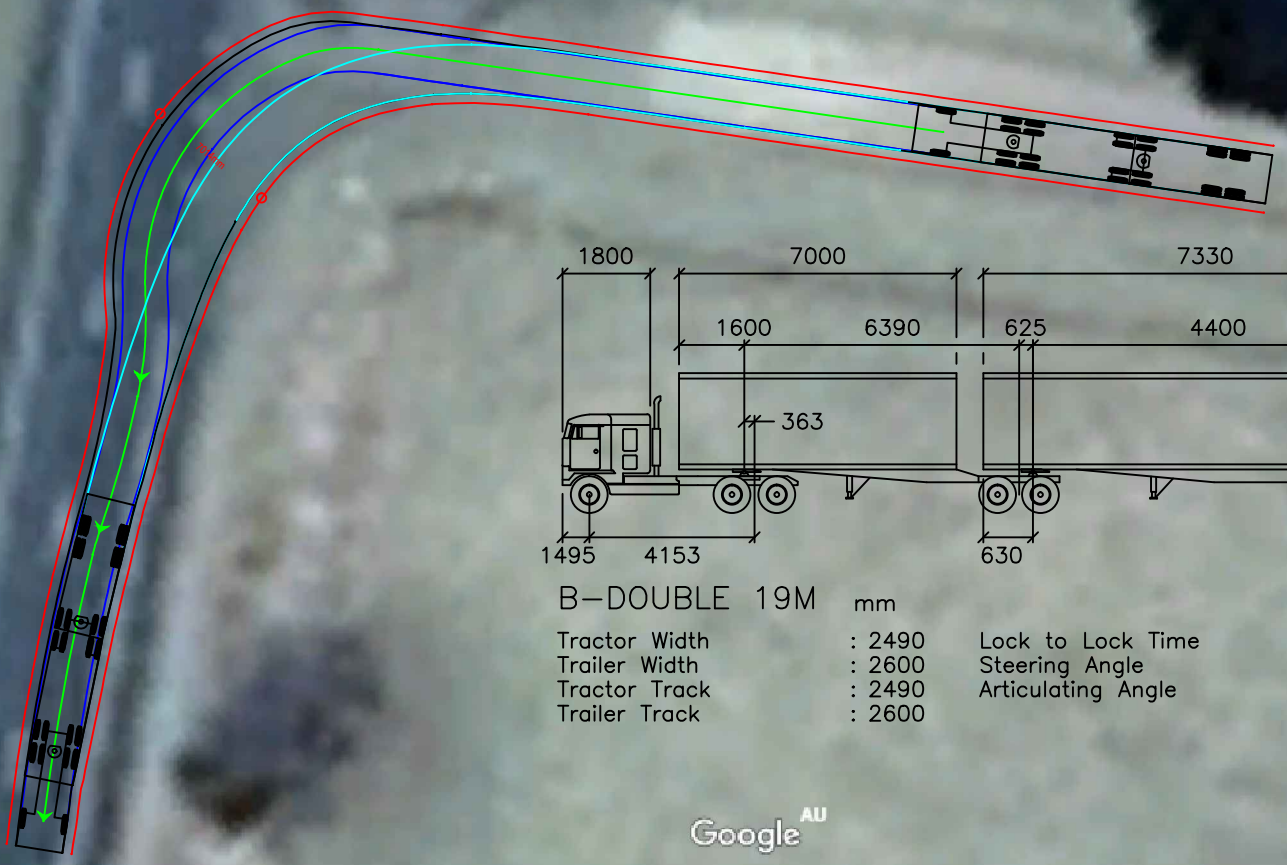
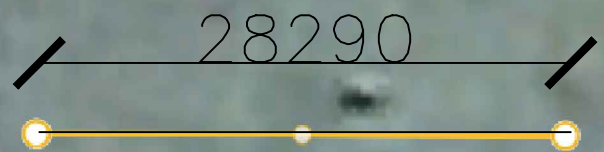

B-DOUBLE 19M mm

Tractor Width	: 2490	Lock to Lock Time	: 6.0
Trailer Width	: 2600	Steering Angle	: 19.4
Tractor Track	: 2490	Articulating Angle	: 70.0
Trailer Track	: 2600		

Google ^{AU}

3D 👤 📍

+ - 🌐 📏

REV. NO.	DESCRIPTION TO REVISION	REV. BY	DATE

Supun Perera

Supun Perera
BE (Hons), MS,
NER, RPEQ, MIEAust, MAITPM
Traffic and Transport Engineer on behalf of APEX Engineers
Mobile: 041 6137635, Email: Info@apexengineers.com.au



CUSTOMER	Owen Pedlow (Jardana Pty Ltd)
PROJECT	34 Pedlows Road, Stonehenge

PROJECT PORTION				19m B-Double Vehicle Swept Path Test	
CHECKED PROPOSAL	APPROVED PROPOSAL	CLIENT APPROVED	ENGINEER APPROVED	DRG No.	REV. 1.0
DRAWN BY:	SCALE N/A	A1	REFERENCE TO:		

Start new X

Distance ?
28.29 m 📄

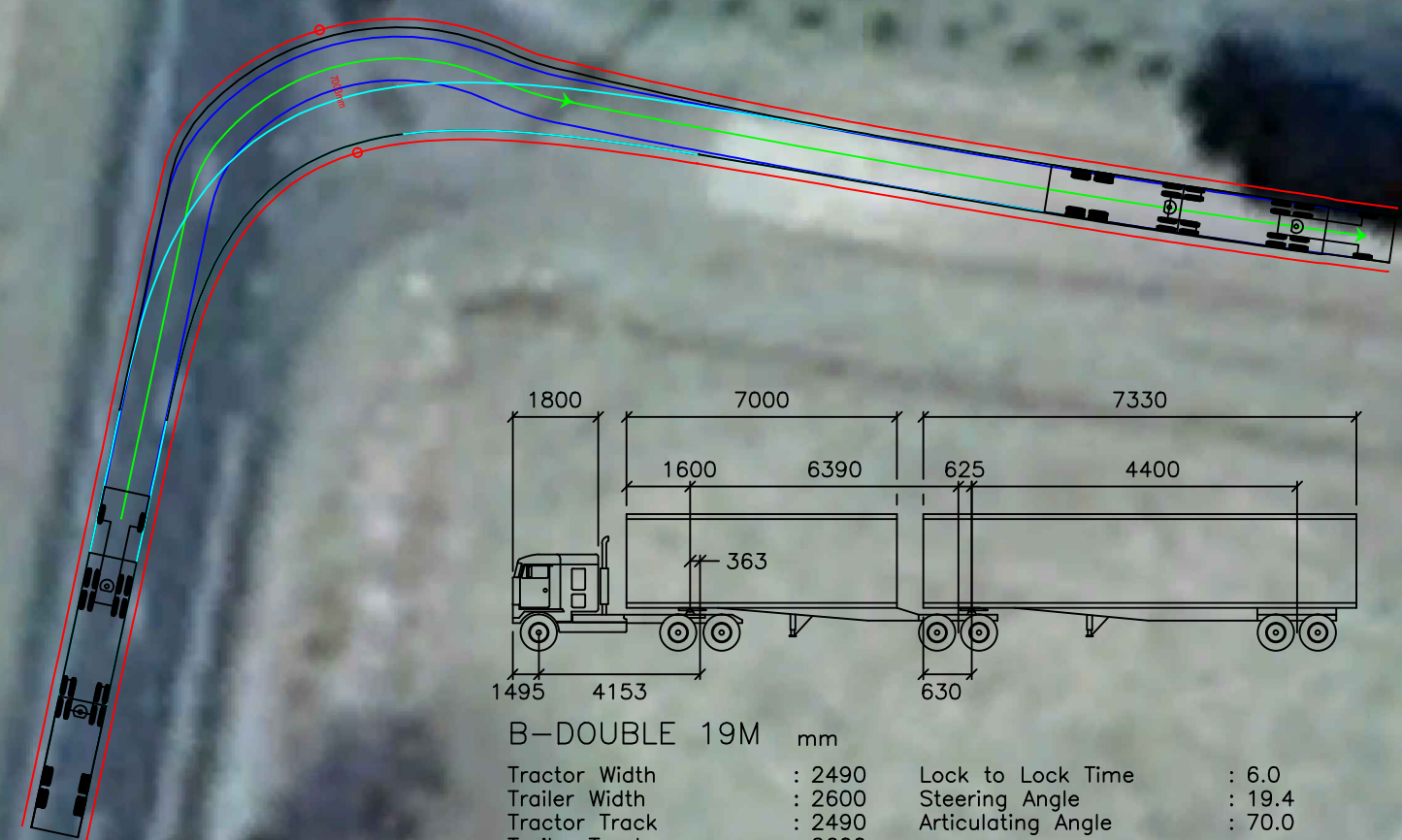
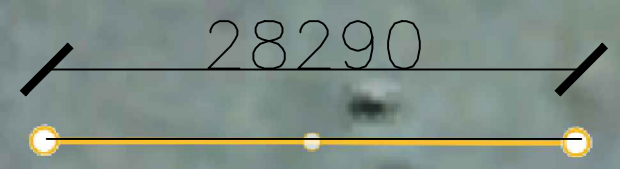

Google AU

3D + -

REV. NO.	DESCRIPTION TO REVISION	REV. BY	DATE

Supun Perera
Supun Perera
BE (Hons), MS,
NER, RPEQ, MIEAust, MAITPM
Traffic and Transport Engineer on behalf of APEX Engineers
 Mobile: 041 6137635, Email: Info@apexengineers.com.au



CUSTOMER: Owen Pedlow (Jardana Pty Ltd)

PROJECT: 34 Pedlows Road, Stonehenge

PROJECT PORTION				19m B-Double Vehicle Swept Path Test	
CHECKED PROPOSAL	APPROVED PROPOSAL	CLIENT APPROVED	ENGINEER APPROVED	DRG No.	REV. 1.0
DRAWN BY:	SCALE: N/A	REFERENCE TO:	A1		



Start new ✕

Distance ?
28.29 m 📄

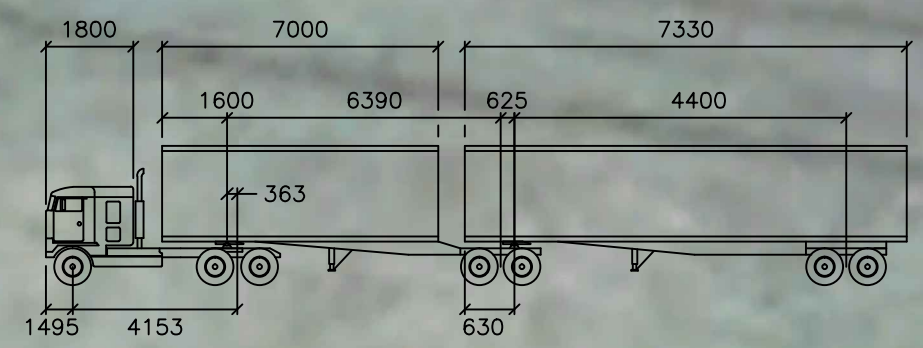
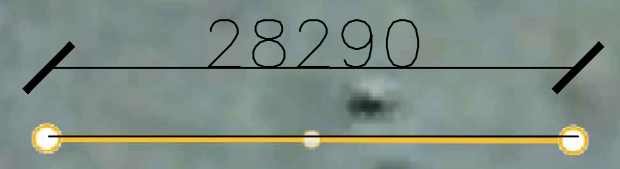

B-DOUBLE 19M mm

Tractor Width	: 2490	Lock to Lock Time	: 6.0
Trailer Width	: 2600	Steering Angle	: 19.4
Tractor Track	: 2490	Articulating Angle	: 70.0
Trailer Track	: 2600		

Google ^{AU}

3D + -

REV. NO.	DESCRIPTION TO REVISION	REV. BY	DATE

Supun Perera

Supun Perera
BE (Hons), MS,
NER, RPEQ, MIEAust, MAITPM
Traffic and Transport Engineer on behalf of APEX Engineers
 Mobile: 041 6137635, Email: Info@apexengineers.com.au



CUSTOMER	Owen Pedlow (Jardana Pty Ltd)
PROJECT	34 Pedlows Road, Stonehenge

PROJECT PORTION				19m B-Double Vehicle Swept Path Test
CHECKED PROPOSAL	APPROVED PROPOSAL	CLIENT APPROVED	ENGINEER APPROVED	
DRAWN BY:	SCALE	REFERENCE TO:	DRG No.	REV. 1.0
	N/A			



apex
ENGINEERS

adding value through
resilient engineering

m 0416 137 635

e info@apexengineers.com.au

w www.apexengineers.com.au

APPENDIX K – WATER & NUTRIENT BALANCE

Feedlot Catchment Parameters

Parameters	Value	Unit
Feedlot Capacity	1,000	SCU
Stocking Density	18	m ² /SCU
Pen Area	1.800	ha
Soft Area	0.391	ha
Hard Area	1.498	ha
Manure Area	0.113	ha
Basin Area	0.125	ha
Pond Area	0.535	ha
<i>Total Area</i>	<i>4.462</i>	<i>ha</i>
<i>Total Area (Excluding) Pond</i>	<i>3.927</i>	<i>ha</i>

Effluent Pond Parameters

Parameters	Value	Unit
Years Modelled In Water Balance	50	years
Initial Pond Volume	1.2	ML
Maximum Pond Volume	8.0	ML
Maximum Pond Depth	2.3	m
Residual Pond Water Depth	0.45	m
Overtopping Incidents	4	No.
Overtopping Frequency - 1 in	12.50	years
Overtopping Percentile	92%	%

Effluent Irrigation Area Parameters

Parameters	Value	Unit
Irrigation Area	54.8	ha
Maximum daily site effluent pump volume	3.0	ML/day
USDA SCS Runoff Model K1	45	
USDA SCS Runoff Model K2	65	
USDA SCS Runoff Model K3	82	

Soil Parameters

Parameters	Value	Unit
Soil Textural Description	Well Structured Clay	
Crop / Pasture Species (Summer)	Sorghum - forage	(November - April)
Crop / Pasture Species (Winter)	Barley	(May - October)
Irrigation Trigger (soil moisture deficit below FC)	25	mm
Crop Root Depth	1.32	m

Irrigation Application Parameters

Parameters	Value	Unit
Irrigation withhold due to Rain	1	mm
Irrigation Method	Low Press Travelling	
Maximum Daily Irrigation Volume	3.00	ML/day
Total Irrigation	0.266	ML/ha/year

Pond Parameters

Parameter	Value	Unit
Volume at Outlet	8.00	ML
Depth at Outlet	2.30	m
Internal Batter (Length)	3.0	h : 1v
Internal Batter (Width)	3.0	h : 1v
Length: Breadth Ratio at TWL	3.00	
Freeboard Depth	0.9	m
Maximum sludge percentage	10%	
Maximum sludge volume	0.80	
Depth at maximum sludge	0.33	

Finished Pond Dimensions

Description	Length	Width	Surface Area	
	(m)	(m)	(m ²)	(ha)
Base (Inside Bed)	102.2	24.9	2,538	0.25
Inside at Natural Surface	121.4	44.1	5,346	0.53
Top Water Level	116.0	38.7	4,482	0.45
Inside Crest	121.4	44.1	5,346	0.53
Outside Crest	121.4	44.1	5,346	0.53

Annual Pond Balance

Year	Inflow (ML)	Rain Addition (ML)	Evaporation (ML)	Irrigation (ML)	Overtopping (ML)
1970	15.6	4.4	2.6	13.5	
1971	14.8	4.2	2.9	20.1	
1972	14.0	4.0	2.9	14.6	
1973	13.5	3.9	2.3	11.1	
1974	12.8	3.7	2.5	18.6	
1975	14.4	4.1	2.5	13.9	
1976	14.4	4.1	2.6	18.0	
1977	13.5	3.9	2.7	14.6	
1978	17.7	5.0	2.5	15.8	
1979	9.9	2.8	2.8	14.4	
1980	7.8	2.2	3.1	6.6	
1981	12.1	3.5	2.8	13.1	
1982	11.3	3.2	2.8	10.9	
1983	15.7	4.5	2.8	12.8	
1984	15.3	4.4	2.6	20.0	2.2
1985	11.9	3.4	2.7	12.7	
1986	9.9	2.8	2.9	9.9	
1987	13.5	3.9	2.7	14.7	
1988	15.5	4.4	2.7	15.4	
1989	16.2	4.6	2.7	18.3	
1990	16.2	4.6	2.8	18.2	1.2
1991	14.5	4.1	2.8	14.3	
1992	14.0	4.0	2.5	16.5	
1993	12.3	3.5	2.5	14.2	
1994	10.3	2.9	2.8	10.4	
1995	14.2	4.1	2.6	15.0	
1996	18.3	5.2	2.9	20.6	
1997	14.9	4.3	2.6	15.8	
1998	15.8	4.5	3.0	15.4	
1999	15.2	4.3	2.6	15.4	
2000	13.3	3.8	2.7	17.0	
2001	17.8	5.1	2.8	22.2	
2002	9.3	2.7	3.0	9.1	
2003	14.5	4.1	2.7	15.9	
2004	15.0	4.3	2.9	16.5	
2005	11.5	3.3	2.7	12.2	
2006	14.8	4.2	2.5	14.6	
2007	14.7	4.2	2.6	15.2	
2008	11.8	3.4	2.3	13.9	
2009	14.5	4.1	2.7	15.7	
2010	15.4	4.4	2.4	8.9	3.7
2011	18.3	5.2	2.5	19.7	4.5
2012	12.2	3.5	2.5	16.9	
2013	10.9	3.1	2.6	11.5	
2014	10.1	2.9	2.7	10.2	
2015	15.0	4.3	2.5	14.7	
2016	14.8	4.2	2.9	16.8	
2017	16.3	4.7	2.7	19.2	
2018	9.8	2.8	2.8	10.4	
2019	4.6	1.3	3.2	2.7	
50 year Avg.	13.5	3.9	2.7	14.5	4.0

Model	Inflow (m3)	Rainfall on Pond (m3)	Evaporation (m3)	Effluent Applied (m3)	Cumulative Storage Volume (m3)	Overflow (m3)
0.4 Universal Runoff - Total	680,670	194,197	135,284	727,924	33,050,511	11,602
0.4 Universal Runoff - Avg.	13,613	3,884	2,706	14,558	661,010	232

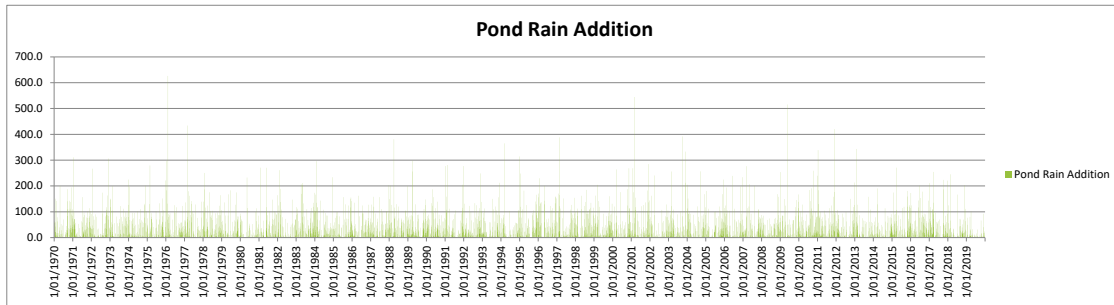
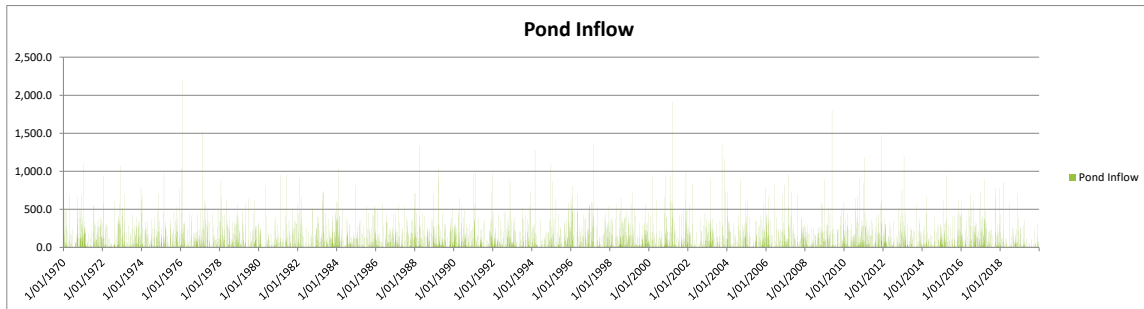
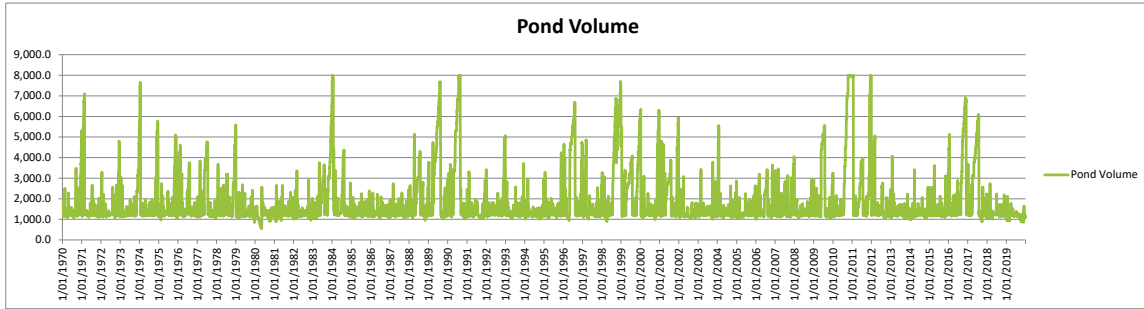

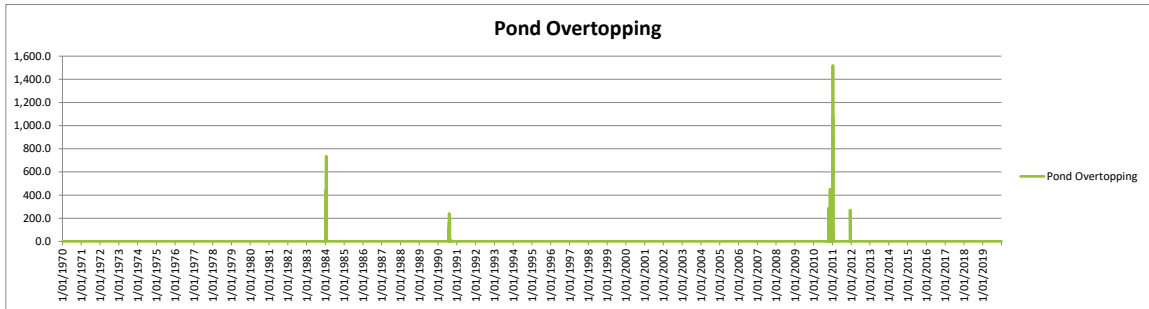
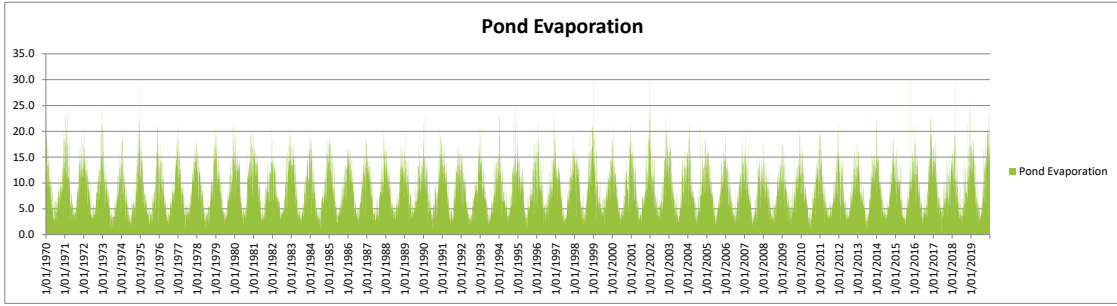
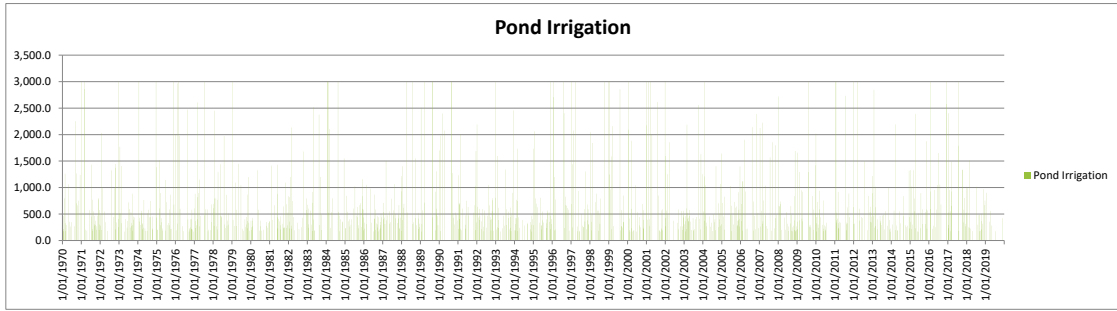

Effluent Reuse Area - Cropping Information

Parameter	Liquid effluent irrigation area	
	Summer	Winter
Crop Period	Forage sorghum	Grain wheat
Crop or fodder produced	15	4
Normal average yield	8	3
Anticipated DM yield (t/ha/yr)	1.80%	1.90%
Dry Matter Nitrogen content	0.30%	0.40%
Dry Matter Phosphorous content	1.90%	0.60%
Dry Matter Potassium content	144	57
Crop Nitrogen removal	24	12
Crop Phosphorous removal	152	18
Crop Potassium removal		

Effluent Reuse Area - Soil Type & Phosphorous Buffering Capacity

Parameter	Effluent Utilisation Area	
Soil type	Black vertosol	
Soil depth to the base of the root zone	1.2	m
Bulk density of the soil	1,300	kg/m ³
Measured P sorption capacity of the soil		mg P/kg soil
P sorption capacity of the soil	73	mg P/kg soil
Safe P storage capacity of soil	1,139	kg/ha

Effluent Reuse Area - Nutrient Uptake

Parameter	Nitrogen	Phosphorous	Potassium	Units
Estimated average annual effluent irrigation volume		14.6		ML/yr
Proposed effluent irrigation method	Travelling Irrigator			
Proposed irrigator type / system	Travelling Irrigator			
Average pond effluent nutrient composition	165	48.75	819	mg/L
N losses during effluent irrigation	15%			
N losses from soil surface following effluent irrigation	10%			
Irrigated effluent available for plant uptake	1,838	710	11,923	kg/yr
Total crop nutrient removal	201	36	170	kg/ha/yr

Effluent Reuse Area - Minimum effluent irrigation areas

Parameter	Nitrogen	Phosphorous	Potassium	Units
Minimum area based on: Total nutrient uptake	9.1	19.7	70.1	ha
Minimum area based on: Soil P Storage (50 year life)		12.1		ha (50 year life)
Minimum required effluent irrigation area				12.1 ha
Maximum effluent application rate				120.57 mm/yr
Proposed effluent irrigation area				54.8 ha
Proposed effluent irrigation application rate				26.6 mm/yr

Effluent Reuse Area - Nutrient balance

Parameter	Nitrogen	Phosphorous	Potassium	Units
Nutrients added (after losses)	1,838	710	11,923	kg/yr
Nutrients added (after losses) per ha	34	13	218	kg/ha/yr
Nutrients removed by crop	11,015	1,973	9,316	kg/yr
Nutrients removed by crop per ha	201	36	170	kg/ha/yr
Nutrient excess per ha	0	0	48	kg/ha/yr
Nutrient deficiency per ha	167	23	0	kg/ha/yr

APPENDIX L – EMERGENCY MANAGEMENT PLAN

Stonehenge Feedlot

Jardana Pty Ltd

Emergency Management Plan (EMP)

**Procedures and responsibilities in response to impacts on
agriculture during emergency situations**

2020

Table of contents

1. Communication	2
1.1 Notification to External Agencies	2
1.2 Notification to Owners/Occupiers in Vicinity of Premises	2
1.3 Contact Details	3
2. Emergency Situations	4
2.1 Evacuation	4
2.2 Flooding	4
2.3 Fire	4
2.4 Disease Outbreak	4
3. Appendices	7
3.1 Eco Logical Australia. 2019 Bushfire Protection Assessment	7
3.2 Pedlows Road Grain Roaster Operations: Bushfire Ready Plan	20
3.3 AUSVETPLAN Operational Procedures Manual: Decontamination	22
3.4 AUSVETPLAN Operational Procedures Manual: Disposal	115

1. Communication

1.1. Notification to External Agencies

- In the case of an emergency situation, the Feedlot Manager will determine the need to notify external agencies and delegate responsibility to carry out actions related to notification.
- In general, the following notification requirements apply:
 - Any emergency situation involving dangerous incident, serious injury, illness or death must be notified to WorkCover **immediately** and notified to insurer within 48 hours.
 - Any emergency situation causing or threatening to cause ‘**material harm**’ to the environment must be reported **immediately** to the **Environmental Protection Authority, NSW Health, NSW Fire and Rescue, WorkCover NSW and the Local Council.**
 - Note:
 - **Immediately** means ‘promptly and without delay’.
 - ‘**Material harm**’ means harm that results in potential or actual loss, or property damage exceeding \$10,000 including post-incident expenses.
 - **All of these authorities are to be notified; whether or not they decide to take action.** Agencies will advise on requirements once informed the nature of the incident.
 - If an emergency disease is suspected the Feedlot Manager will contact consultant veterinarian and relevant authority through the district veterinary officer or emergency disease hotline.
 - If an excessive heat load occurs the Feedlot Manager will contact the consultant veterinarian and relevant resources.

1.2. Notification to Owners/Occupiers of Premises in Vicinity

In the case of a pollution incident threatening material environmental harm, owners/occupiers will be contacted as soon as practicable with regular updates made. Mechanisms for communication may include the following:

- telephone calls;
- personal contact by vehicle;
- radio/ UHF (channel 36); and/or
- emails.

Information communicated will include:

- Type of incident and risk to owners/ occupiers
- Plan and procedure in place for ongoing action
- Responsibilities

1.2 Contact Details

National Emergency	000
National Animal Disease Watch Hotline	1800 675 888
Local veterinarian:	
Glen Innes	(02) 6732 1988
Guyra	(02) 6779 1173
Environmental Protection Authority	(02) 6640 2500
NSW Health	1300 066 055
NSW Fire and Rescue	(02) 9265 2999
WorkCover NSW	13 10 50
Glen Innes Severn Council	(02) 6730 2300
<u>After hours:</u>	
Rangers	0417 890 889
Water and Wastewater	0418 162 794
Environmental Pollution Incident	0428 669 871
Roads and drainage	0409 817 242

2. Emergency situations

2.1. Evacuation

- Evacuation may be evaluated and instigated in response to natural disaster, fire or explosion, gas leaks, fuel and chemical spills, confined space incident and structural faults.
- The Evacuation and Emergency Control Point is at the ‘residential dwelling’ of 34 Pedlow’s Rd, as stated in appendices 3.2, *Pedlows Road Grain Roaster Operations: Bushfire Ready Plan*.

2.2. Flooding

- Refer to evacuation procedures above.

2.3. Fire

- Refer to evacuation procedures above.
- There will be fire extinguishers present and maintained at both the feedlot and grain roaster/storage sites.
- Refer to appendices 3.1, *Eco Logical Australia. 2019 Bushfire Protection Assessment: 34 Pedlow's Road, Stonehenge* and 3.2, *Pedlows Road Grain Roaster Operations: Bushfire Ready Plan*.

2.4. Disease outbreak

- Responding to a disease outbreak will involve the actions described below in accordance with Animal Health Australia and Australia’s Veterinary Emergency Plan (AUSVETPLAN).

Before an outbreak:

- Provide training for staff in disease recognition, biosecurity and hygiene, and procedures for reporting notifiable disease.

- Review farm biosecurity. Assess whether visitors present a risk and manage their contact with the animals.
- Establish and use effective quarantine (isolation) facilities on the farm for newly-arrived or sick livestock.
- Review farm biosecurity. Assess whether visitors present a risk and manage their contact with the animals.
- Monitor and control feral animal populations using humane and legal means.
- Ensure cleanliness and tidiness of the premises to facilitate rapid decontamination
- Review your property's insurance to determine the implications of a disease outbreak and to ensure policies are up to date.
- Ensure the layout and design of premises and wash-down sites are convenient and provide for rapid cleaning with minimal damage to infrastructure.
- Consider where and how you could decontaminate heavy equipment (e.g. trucks) on your property.

During an outbreak:

- Contact all relevant authorities and personnel listed in contact details (1.2)
- Enhance biosecurity procedures on infected and susceptible premises (quarantine zones and buffers) and/or movement restrictions for cattle, vehicles and people.
- Ensure adequate supply and storage of clean water and disinfectant for decontamination requirements. Refer to appendices 3.3, *AUSVETPLAN Operational Procedures Manual: Decontamination* for appropriate information on disinfectant/decontamination agents to be used.
- Where possible, seal transport trucks to prevent leakage of manure or urine if animals are permitted to be transported.
- Communicate clearly with appropriate industries and personnel to direct the media to a central point and prevent misinformation and/or undue fear.
- Keep records of disease control measures and other activities on your property during the response.

After an outbreak:

- Release movement and quarantine restrictions
- Determine the length of a fallow period required for infected areas
- Repopulation: Depending on the disease agent, animals may be required to test negative prior to introduction

Responsibilities

Responsibilities of the enterprise in response to an emergency disease case involve the following:

- Effective communications between agencies and neighbouring residencies
- Biosecurity regulations
- Implementation of isolation and decontamination of potentially infected livestock and livestock.
- Appropriate training for employees
- Vaccination (staff and animals), cleaning and disinfection as required

Not all livestock disease incidents will require local, state, or federal emergency response actions.

For methods of disposal, refer to appendices 3.4, *AUSVETPLAN Operational Procedures Manual: Disposal*.

Personal Protective Equipment

When the causative agent is unknown or unmanageable, high levels of protection may be used. Once the agent is identified, levels of protection can be adjusted to fit specific challenges an agent might pose.

Appendices

- 3.1. 'Eco Logical Australia. 2019 Bushfire Protection Assessment: 34 Pedlow's Road, Stonehenge.'
- 3.2. Pedlows Road Grain Roaster Operations: Bushfire Ready Plan
- 3.3. AUSVETPLAN Operational Procedures Manual: Decontamination
- 3.4. AUSVETPLAN Operational Procedures Manual: Disposal

APPENDIX M – BUSHFIRE PROTECTION ASSESSMENT

A decorative background element consisting of a topographic map with contour lines, rendered in a light grey color. The map is positioned on the left side of the page, extending from the top to the bottom.

Bushfire Protection Assessment: 34 Pedlow's Road, Stonehenge

Kaylene A Pedlow

DOCUMENT TRACKING

Project Name	Bushfire Protection Assessment: 34 Pedlow's Road, Stonehenge
Project Number	19WOL_13436
Project Manager	Mick George
Prepared by	Letara Judd
Reviewed by	Mick George
Approved by	Mick George
Status	Final
Version Number	v1
Last saved on	10 July 2019

This report should be cited as 'Eco Logical Australia. 2019 Bushfire Protection Assessment: 34 Pedlow's Road, Stonehenge. Prepared for Kaylene A Pedlow.'

Disclaimer

This document may only be used for the purpose for which it was commissioned and in accordance with the contract between Eco Logical Australia Pty Ltd and Kaylene A Pedlow. The scope of services was defined in consultation with Kaylene A Pedlow, by time and budgetary constraints imposed by the client, and the availability of reports and other data on the subject area. Changes to available information, legislation and schedules are made on an ongoing basis and readers should obtain up to date information. Eco Logical Australia Pty Ltd accepts no liability or responsibility whatsoever for or in respect of any use of or reliance upon this report and its supporting material by any third party. Information provided is not intended to be a substitute for site specific assessment or legal advice in relation to any matter. Unauthorised use of this report in any form is prohibited.

Contents

1. Property and proposal	1
1.1 Description of proposal	1
1.2 Location and description of land	1
1.3 Bush fire prone land status.....	1
2. Bushfire threat assessment	3
2.1 Vegetation types and slope	3
3. Asset Protection Zones	5
4. APZ maintenance plan	5
5. Construction standard	6
6. Water Supply	6
7. Gas and Electrical Supply	6
8. Access	7
9. Assessment of environmental issues	7
10. Conclusion and Recommendations.....	8
11. References	9

List of Figures

Figure 1: Location of Grain Roaster and Gas Cylinders	2
Figure 2: Bushfire hazard assessment and Asset Protection Zones (APZ)	4

List of Tables

Table 1: Subject site summary	1
Table 2: Determination of APZ and construction standard	5

1. Property and proposal

Table 1: Subject site summary

Street address or property name:	34 Pedlow's Road		
Suburb, town or locality:	Stonehenge	Postcode:	2370
Lot/DP no:	Lot 1 DP 308507		
Local Government Area:	Glen Innes Severn		
Zoning:	RU1 Primary Production		
Type of development:	Class 8 Grain Roaster		

1.1 Description of proposal

Kaylene O Pedlow commissioned Eco Logical Australia Pty Ltd (ELA) to prepare a bushfire protection assessment (BPA) for a proposed Grain Roaster to support agricultural activities at 34 Pedlow's Road, Stonehenge (hereafter referred to as the 'subject land').

The proposed development consists of a re-locatable gas-powered Grain Roaster. The Grain Roaster is operated on an occasional basis to cook grain on-site and utilises three gas cylinders with storage capacity of 6,000 L each. The proposed development is located within an existing operational farming enterprise.

This desktop assessment is based on information provided by the client (photos and location plan) and online information from Google Earth and Sixmaps.

1.2 Location and description of land

The subject land is located on approximately 550 ha of pastured land used for livestock agricultural purposes located 10 km south of Glen Innes. The subject land includes an existing dwelling, sheds, silos and farming equipment.

Figure 1 shows a plan of the development.

1.3 Bush fire prone land status

The subject land includes land classified as bush fire prone on the Glen Innes Severn's bush fire prone land (BFPL) map¹.

¹ <https://www.planningportal.nsw.gov.au/find-a-property>

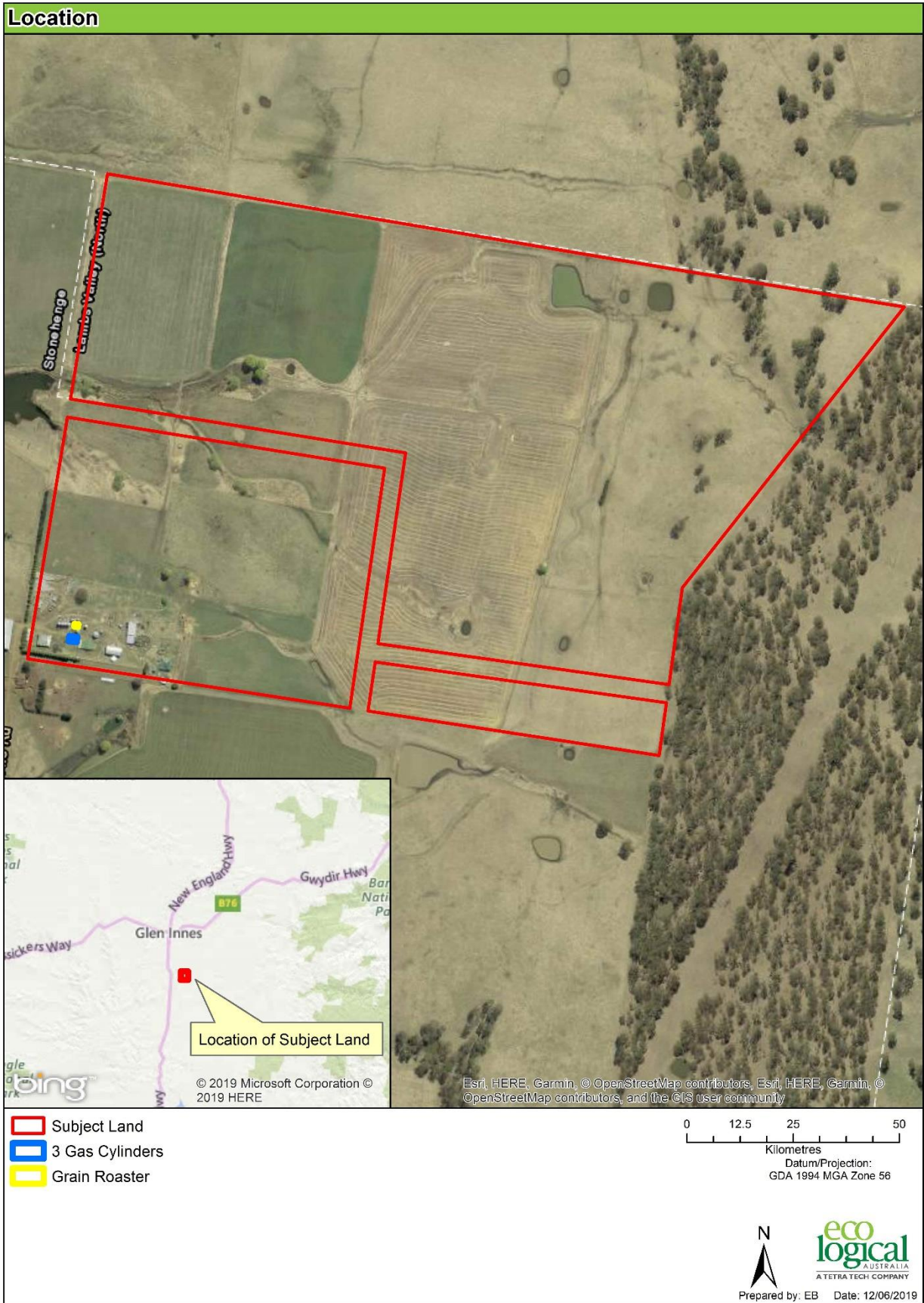

Figure 1: Location of Grain Roaster and Gas Cylinders

2. Bushfire threat assessment

The subject land is identified as bush fire prone land by Glen Innes Severn Council. In accordance with Section 4.14 (formerly Section 79BA) of the *Environmental Planning and Assessment Act 1979*, this report demonstrates that the proposal, together with the recommendations within this report conform to the relevant specifications and requirements under *Planning for Bush Fire Protection 2018* (herein referred to as PBP).

2.1 Vegetation types and slope

In accord with PBP the predominant vegetation class has been assessed for a distance of at least 140 m out from the proposed development and the slope class 'most significantly affecting fire behaviour' has been determined for a distance of at least 100 m in all directions. The predominant vegetation and effective slope assessments are shown in **Table 2**.

In all directions, the predominant vegetation type influencing the proposed development is classified as 'Grassland' under PBP. The effective slope under the vegetation falls into the PBP slope category of 'all upslopes and flat land'.

The site is located within the Local Government Area (LGA) of Glen Innes Severn and has a Fire Danger Index (FDI) of 80.



Figure 2: Bushfire hazard assessment and Asset Protection Zones (APZ)

3. Asset Protection Zones

Table A1.12.6 of PBP-2018 has been used to determine the width of any required Asset Protection Zone (APZ) for the proposed development using the vegetation and slope data identified in **Section 2**. **Table 2** outlines the APZ requirements for the proposed development.

Table 2: Determination of APZ and construction standard

Direction	Slope ¹	Vegetation ²	Proposed APZ	AS3959-2018 Bushfire Attack Level (BAL) ³	Comments
All directions	All upslope and flat land	Grassland	50 m	BAL-LOW	APZ to be provided for the life of the development.

¹ Effective slope assessed over 100 m from proposed development where the bushfire hazard occurs.

² Predominant vegetation classification over 140 m from proposed development.

³ Bushfire Attack Level (BAL) corresponding to construction requirements as determined by AS 3959-2018 'Construction of buildings in bushfire-prone areas' (Table 2.5).

4. APZ maintenance plan

Where the APZ is to be established it is to be managed to Inner Protection Area standards as follows:

Grass:

- should be kept mown (as a guide grass should be kept to no more than 100mm in height)
- leaves and vegetation debris should be removed.

Further details on APZ implementation and management can be found on the NSW RFS website including:

https://www.rfs.nsw.gov.au/_data/assets/pdf_file/0010/13321/Standards-for-Asset-Protection-Zones.pdf.

5. Construction standard

The proposed development includes no proposed building, as such there are no applicable construction standards. However, in consideration of the operational activities proposed, an APZ is proposed to meet BAL-LOW.

6. Water Supply

The subject land is not serviced by reticulated water. The Grain Roaster and gas cylinders have access to 100,000 L water tank located at the milling area. A firefighting pump is attached to the tank with 50 mm snap lock fittings. The tank is located in a shed within 100 m of operations.

It is recommended that a connection for firefighting purposes (65mm Storz outlet with a ball valve) is fitted to the tank for firefighting purposes, as the current fittings would not allow connection from RFS appliances.

The property owner is encouraged to place a 'SWS' (static water supply) sign in a visible location for static water supplies. Periodic testing of firefighting equipment should also occur to ensure that it is maintained in working order. It is recommended that the owner consider a fire cart/slip on unit to be stationed nearby the grain roaster during the operation of the roaster on severe and above fire danger rating days to provide rapid response firefighting capabilities in the event of a grass fire.

7. Gas and Electrical Supply

There existing electricity supply is above ground. The overhead electrical transmission lines are compliant with Section 5.3.4 of PBP, subject to the following specifications:

- lines are installed with short pole spacing (30m), unless crossing gullies, gorges or riparian areas;
- no part of a tree is closer to a power line than the distance set out in accordance with the specifications in ISSC3 Guideline for Managing Vegetation Near Power Lines

The three LPG gas cylinders with storage capacity of 6,000 L each, are compliant with Section 5.3.4 of PBP, subject to the following specifications:

- Reticulated or bottled gas is installed and maintained in accordance with AS/NZS 1596:2014 and the requirements of relevant authorities, and metal piping is used;
- All fixed gas cylinders are kept clear of all flammable materials to a distance of 10 m and shielded on the hazard side;
- Connections to and from gas cylinders are metal;
- Polymer-sheathed flexible gas supply lines are not used; and
- Above-ground gas service pipes are metal, including and up to any outlets.

8. Access

The proposed development is located on Pedlow's Road.

The Grain Roaster is located in an existing operational area and is access by an internal unsealed road of approximately 50 m length, located in Grassland, with appropriate turning area for fire fighting vehicles.

This development does not propose any additional access.

9. Assessment of environmental issues

An assessment of significant environmental features, threatened species or Aboriginal relics identified under the *Biodiversity Conservation Act 2016* or the *National Parks Act 1974* that will affect or be affected by the bushfire protection proposals in this report has not been undertaken as it is covered by other parts of the DA process. However, site impacts have been minimised by carefully selected bushfire protection measures. The impact footprint of these measures e.g. APZ is clearly identified within this report and therefore capable of being clearly assessed by suitably qualified persons as required.

Glen Innes Severn Council is the determining authority for this development; they will assess more thoroughly any potential environmental and heritage issues.

10. Conclusion and Recommendations

The proposal consists of a re-locatable Grain Roaster and 3 associated LPG gas cylinders located a minimum of 50 m from the nearest bushfire hazard. It can achieve the aim and objectives of PBP.

The following recommendations apply:

1. An Asset Protection Zone of 50 m in all directions is to be established and maintained for the life of the development as an Inner Protection Area;
2. An existing 100,000 L water tank is supplied at the development area;
3. A connection for firefighting purposes (65mm Storz outlet with a ball valve) is fitted to the tank for firefighting purposes;
4. The owner should consider a fire cart/slip on unit to be stationed nearby the grain roaster during the operation of the roaster on severe and above fire danger rating days to provide rapid response firefighting capabilities in the event of a grass fire
5. The property owner is encouraged to place a 'SWS' (static water supply) sign in a visible location for static water supplies
6. Access to the development area is existing and adequate turning area is provided for fire fighting vehicles;
7. The existing LPG gas cylinders are to be maintained in accordance with Australian Standard AS/NZS 1596 'The storage and handling of LP Gas' (Standards Australia 2014) and the requirements of relevant authorities (metal piping must be used).

In the author's professional opinion, the bushfire protection requirements listed in this assessment provide an adequate standard of bushfire protection for the proposed development, a standard that is consistent with 'Planning for Bush Fire Protection 2018' (RFS 2018).



Letara Judd
Bushfire Consultant

11. References

Industry Safety Steering Committee 3 (ISSC3). 2016. ISSC3 Guide for the Management of Vegetation in the Vicinity of Electricity Supply Infrastructure. November 2016. NSW.

Keith, D. 2004. *Ocean Shores to Desert Dunes*. Department of Environment and Conservation, Sydney.

NSW Rural Fire Service (RFS). 2018. *Pre-Release Planning for Bush Fire Protection: A Guide for Councils, Planners, Fire Authorities and Developers*

Standards Australia (SA). 2009. Construction of buildings in bushfire-prone areas (including Amendments 1 – 3), AS 3959-2009. SAI Global, Sydney.

Standards Australia (SA). 2014. *The storage and handling of LP Gas*, AS/NZS 1596:2014. SAI Global, Sydney.

